

ESCH - 5605 DRILL

Operator's Manual and Parts List



Seed Calibrations and Settings

- Remove plastic from frame (see Fig. A).
- Place plastic under drill to collect seeds for calibration (see Fig. B).
- See seed chart on lid for further instructions. Note: Be sure to turn drive wheel the correct direction. **WARNING: turning drive wheel too fast will result in wrong calibration. Turn wheel at ground speed.**
- When placing seed in hopper, keep seed baffles down (see Fig.C).
- Keep baffles in up position when seeding fluffy seed.

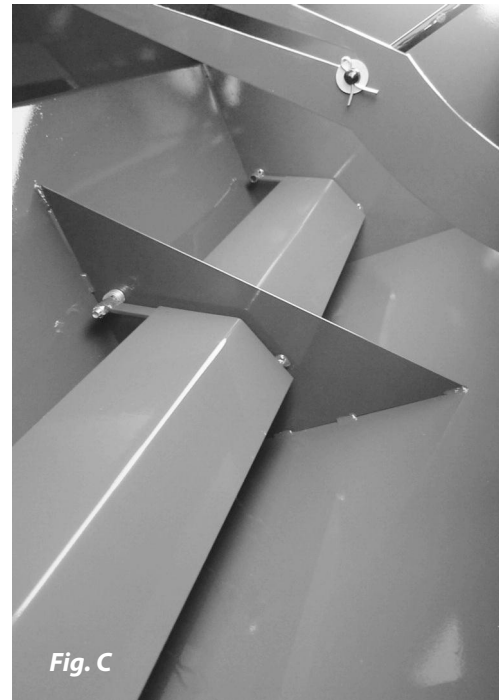
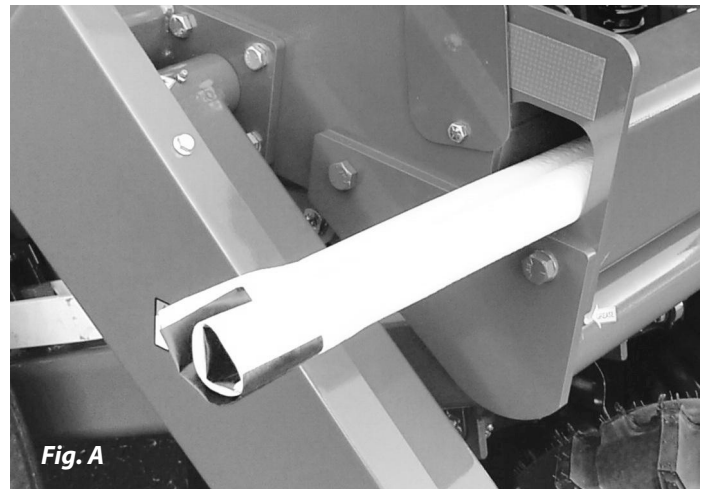

Setting Seeding Depth

- No-till coulters depth can only be set by lowering and raising drill.
- Set no-till coulters approximately 1/2" to 1" deeper than seeding depth.
- Seeding depth can be adjusted by sliding T-handle forward for shallow and backward for deeper.

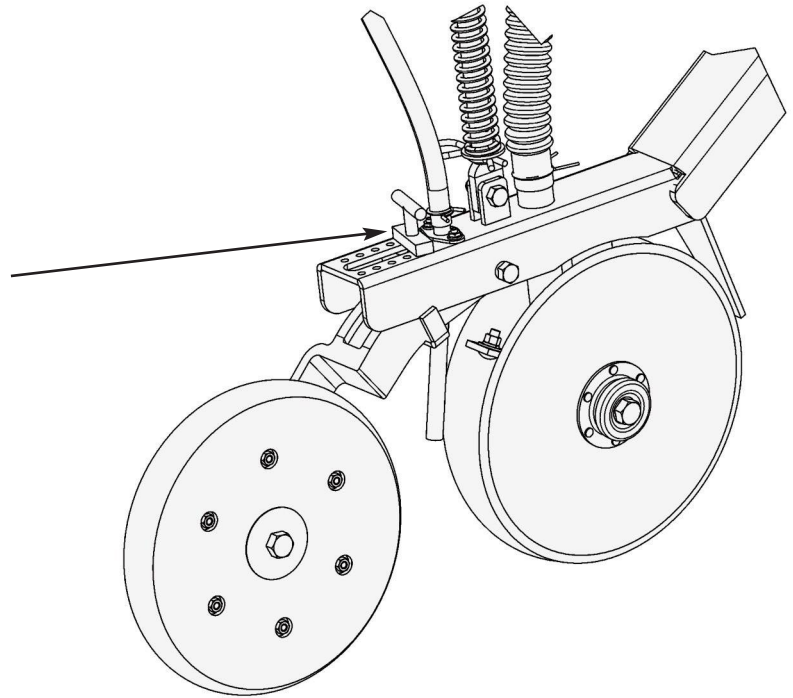

Safety

- Do not ride on drill while moving.
- Do not make sharp turns while drill is down.
- Raise drill when going over rocks that are above ground.

Storage

- Do not store in area where there are lots of mice. Mice like to chew the foams if they can get in the seed box.

Maintenance

- Grease coulters arms: every 10 hours. **(A)**
- Grease coulters hubs: every 50 hours. **(B)**
- Grease all other zerks: every 20 hours.

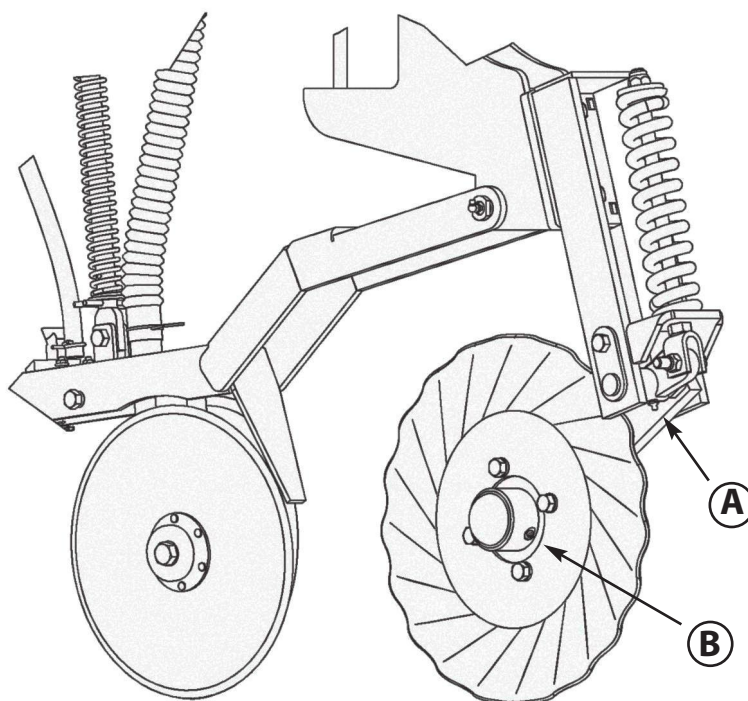

Replacing Foams

- Remove shield on back side of drill (wing nuts).
- Remove shield on left side of seed box.
- Loosen set screws where square shaft slides into round coupler.
- Now shaft is ready to pull out.
- Foam can be cut from plate with a sharp knife or razor.
- Set foams and plate on a piece of card board.
- Spray foams and plates with a spray adhesive.
- Leave set for approximately 1 minute before setting foam on plate.

Trouble Shooting

1 - Seed flows faster on one row:

Foam may be torn or mouse may have chewed a hole in the foam.

2 - One side of drill is lower than other side:

Raise drill the whole way up to realign.

FRAME ASSEMBLY - 5605 DRILL

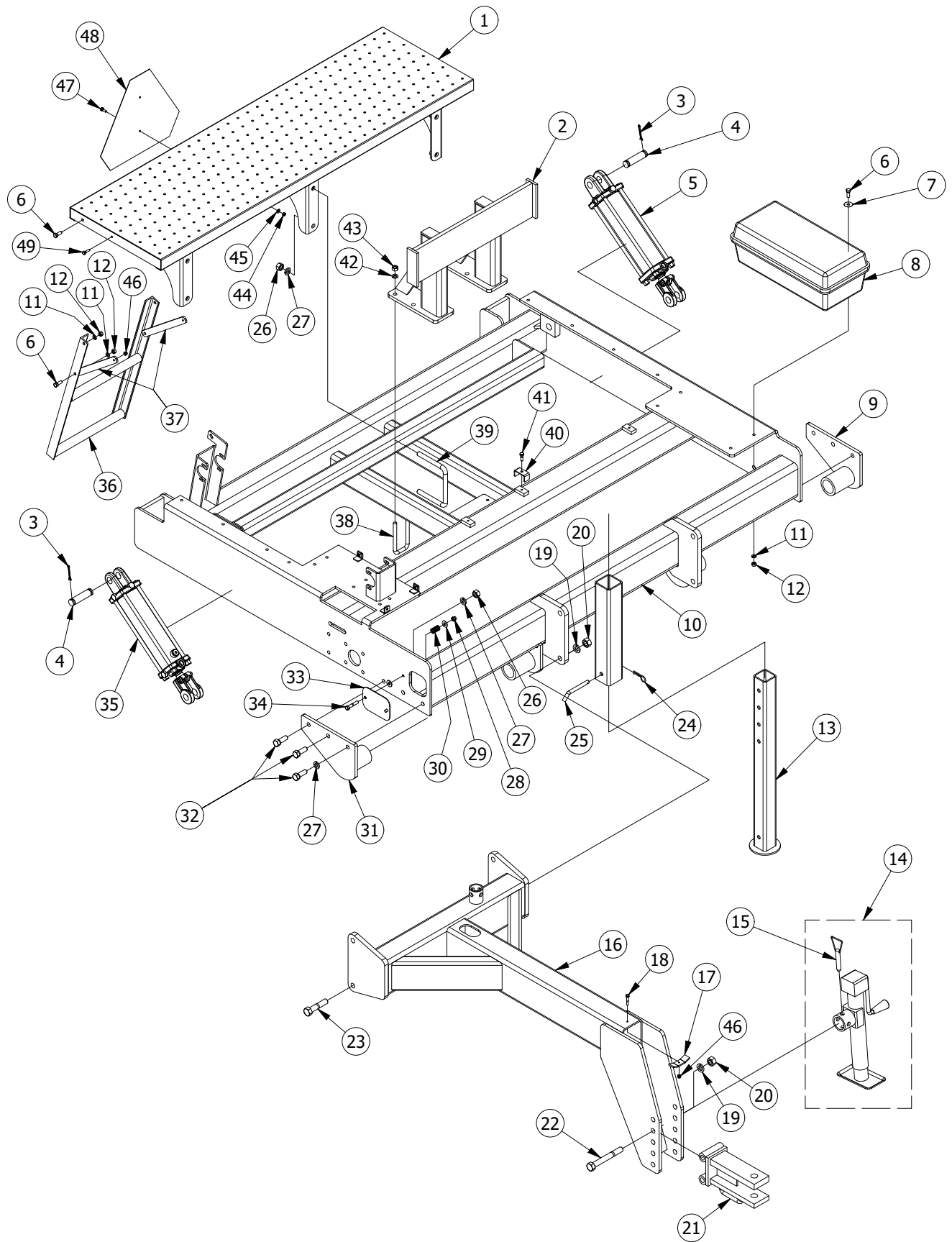

FRAME ASSEMBLY - 5605 DRILL

PARTS LIST				
ITEM	QTY	PART NUMBER	DESCRIPTION	COMMENTS
1	1	113120	STEP	
2	1	113220	WEIGHT BRACKET	
3	4	91100800	5/32 x 2 COTTER PIN	
4	2	1124	PIN	
5	1	1106	HYDRAULIC CYLINDER	SEAL KIT - 1106K
6	8	12416045	3/8-16 UNC X 1 HEX BOLT	
7	4	72405000	FENDER WASHER	
8	1	1115	TOOL BOX	
9	1	110820	SUPPORT - LEFT	
10	1	113020	FRAME - 5 FT DRILL	
11	8	62400000	3/8 LOCK WASHER	
12	8	32416005	3/8 - 16 HEX NUT	
13	1	111020	TRANSPORT JACK	
14	1	1101	JACK	
15	1	1102	PIN	
16	1	113320	TONGUE	
17	1	111220	HOSE HOLDER	
18	1	11620065	HEX BOLT	
19	6	64800000	3/4 LOCK WASHER	
20	6	34810005	3/4 - 10 HEX NUT	
21	1	110320	HITCH	
22	2	14810245	3/4-10 UNC X 6 HEX BOLT	
23	4	14810145	3/4-10 UNC X 3.5 HEX BOLT	
24	1	1128	1/8 HAIRPIN	
25	1	1111	PIN	
26	10	34011005	5/8 - 11 HEX NUT	
27	12	64000000	5/8 LOCK WASHER	
28	1	52416005	3/8 - 16 HEX LOCK NUT	
29	2	72400000	3/8 WASHER	
30	1	1613	SPRING	
31	1	110920	SUPPORT RIGHT	
32	6	14011075	5/8-11 UNC X 1.75 HEX BOLT	
33	1	112320	TARP COVER	
34	1	12416085	3/8-16 UNC X 2 HEX BOLT	
35	1	1107	HYDRAULIC CYLINDER	SEAL KIT - 1107K
36	1	112020	LADDER	
37	2	112120	BRACE	
38	4	1117	U BOLT	
39	3	1118	U BOLT	
40	4	1075	HOSE CLIP	
41	4	12018045	5/16-18 UNC X 1 HEX BOLT	
42	8	63200000	1/2 LOCK WASHER	
43	8	33213005	1/2 - 13 HEX NUT	
44	2	31620005	1/4 - 20 HEX NUT	
45	2	62000000	5/16 LOCK WASHER	
46	3	51620002	1/4 - 20 HEX LOCK NUT	
47	2	11620035	1/4-20 UNC X 0.75 HEX BOLT	
48	1	1122	SMV	
49	2	11620045	1/4-20 UNC X 1 HEX BOLT	

LIFT WHEEL - 5605 DRILL

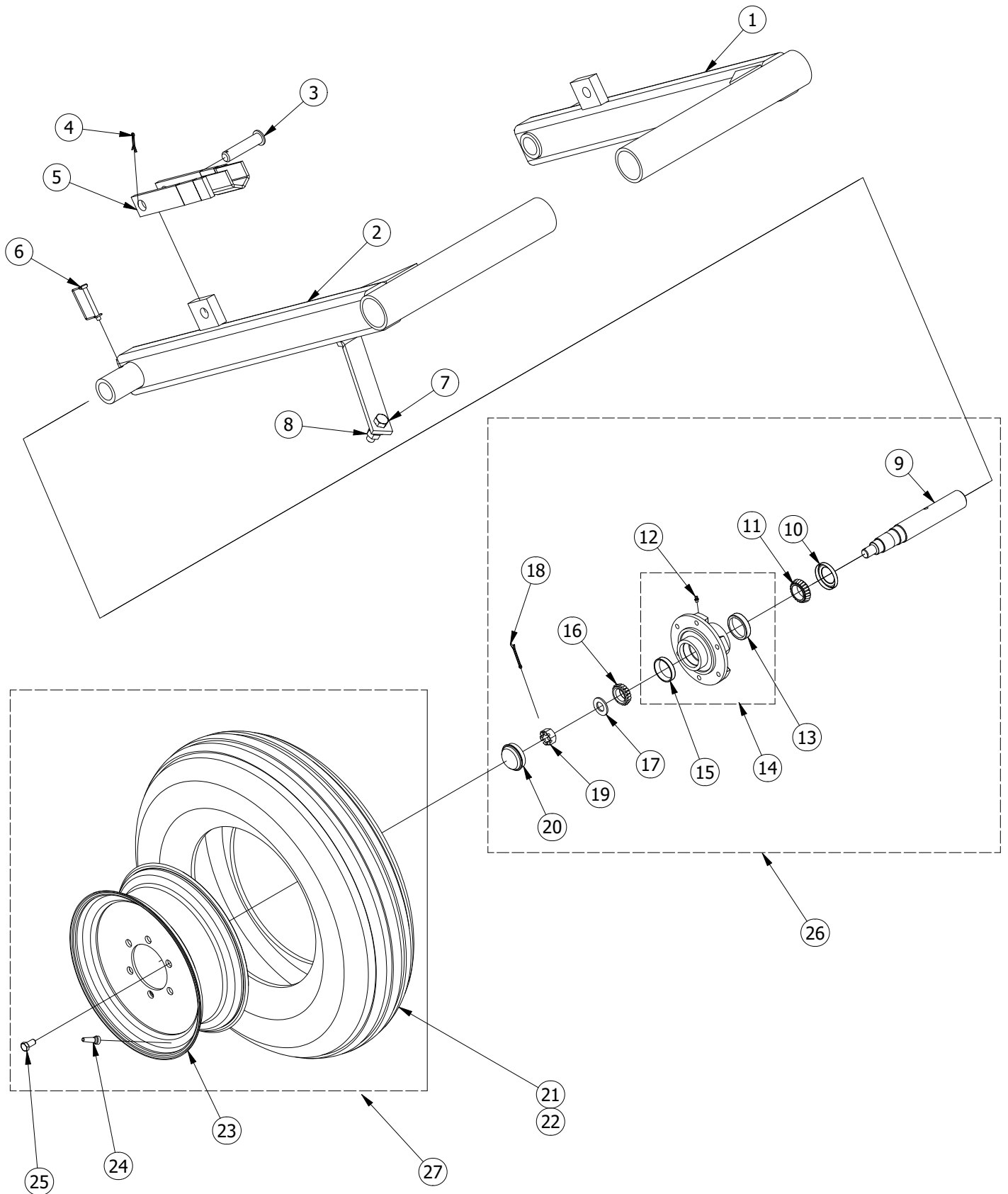

LIFT WHEEL - 5605 DRILL

PARTS LIST				
ITEM	QTY	PART NUMBER	DESCRIPTION	COMMENTS
1	1	115220	LEFT LIFT ARM	
2	1	115120	RIGHT LIFT ARM	
3	2	1167	PIN	
4	2	91120600	3/16 x 1 1/2 COTTER PIN	
5	2	1166	CYLINDER PROP	
6	2	1153	LOCK PIN	
7	1	14810105	3/4-10 UNC X 2.5 HEX BOLT	
8	1	34810005	3/4 - 10 HEX NUT	
9	2	115420	SPINDLE	
10	2	1156	SEAL	
11	2	1158	BEARING	
12	2	Z1428	ZERK	
13	2	1157	BEARING CUP	
14	2	115520	HUB	INCLUDES 1157, 1159, Z1428
15	2	1159	BEARING CUP	
16	2	1160	BEARING	
17	2	85600000	7/8 SAE WASHER	
18	2	91100800	5/32 x 2 COTTER PIN	
19	2	1663	7/8 - 14 SLOTTED HEX NUT	
20	2	166420	HUB CAP	
21	2	1162	TIRE	
22	1	1161	INNER TUBE	
23	2	116320	RIM	
24	2	1190	VALVE STEM	
25	12	1512	LUG BOLT	
26		118220	SPINDLE AND HUB ASSEMBLY	
27		116520	WHEEL ASSEMBLY	INCLUDES 116320, 1161, 1162, 1190

DRIVE ARM - 5605 DRILL

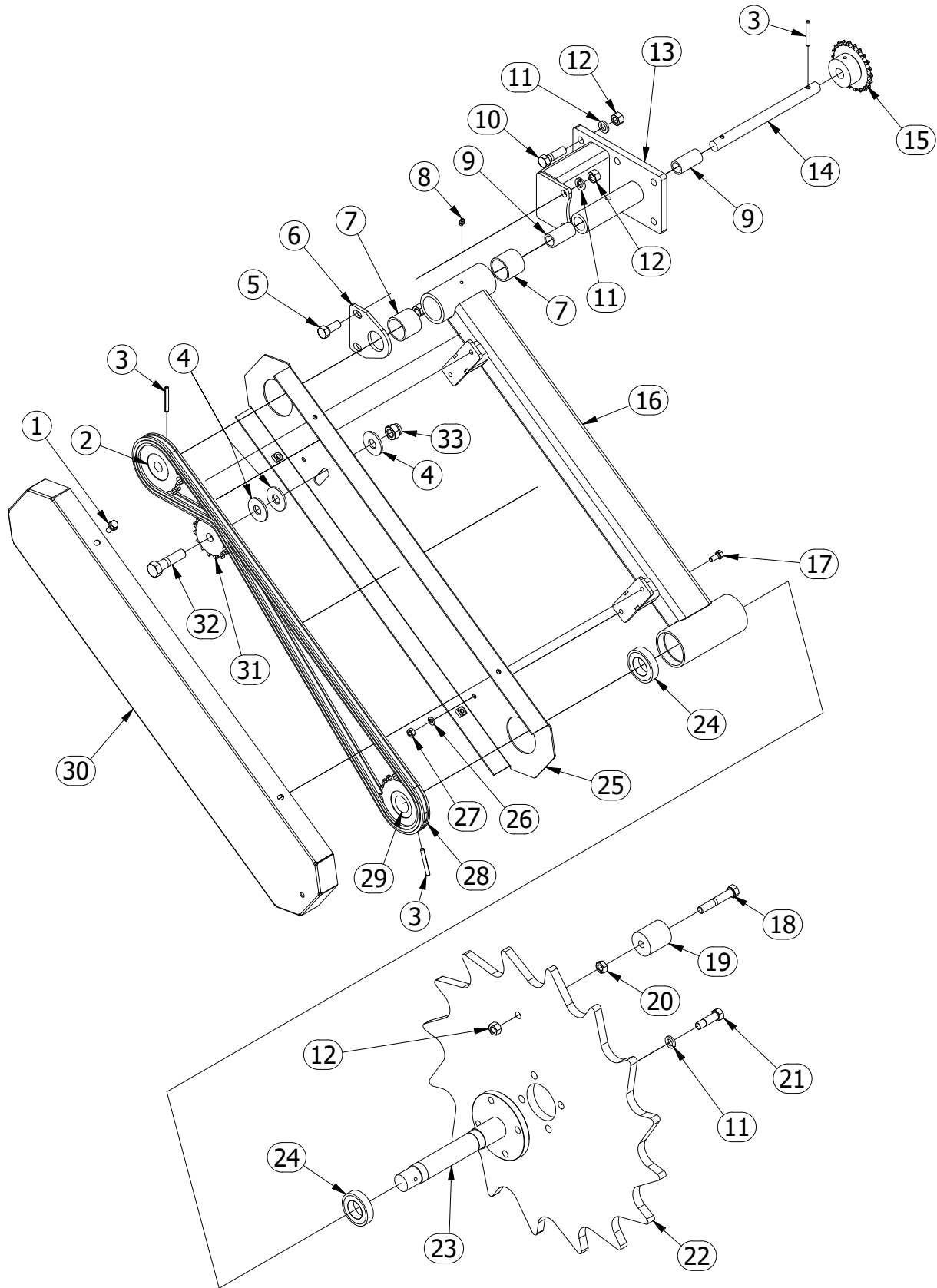

DRIVE ARM - 5605 DRILL

PARTS LIST				
ITEM	QTY	PART #	DESCRIPTION	COMMENTS
1	4	12018032	5/16-18 X 0.75 FLANGE BOLT	
2	1	1517	SPROCKET - 20T	
3	3	93160800	1/4 x 2 ROLL PIN	
4	3	74000000	5/8 WASHER	
5	2	13213055	1/2-13 UNC X 1.25 HEX BOLT	
6	1	150220	SUPPORT	
7	2	1518	BUSHING	
8	1	Z1428	ZERK	
9	2	1519	BUSHING	
10	6	13213075	1/2-13 UNC X 1.75 HEX BOLT	
11	12	63200000	1/2 LOCK WASHER	
12	9	33213005	1/2 - 13 HEX NUT	
13	1	150120	SUPPORT	
14	1	1520	SHAFT	
15	1	1527	SPROCKET - 22T	
16	1	153120	DRIVE WHEEL ARM	
17	4	12018035	5/16-18 UNC X 0.75 HEX BOLT	
18	1	13213128	1/2-13 UNC X 3 HEX BOLT	
19	1	1511	SLEEVE	
20	1	53213002	1/2 - 13 HEX JAM NUT	
21	4	13220075	1/2-20 UNF X 1.75 HEX BOLT	
22	1	1521	STEEL DRIVE WHEEL	
23	1	153220	DRIVE WHEEL SPINDLE	
24	2	153320	BEARING	
25	1	153520	DRIVE ARM INNER SHIELD	
26	4	62000000	5/16 LOCK WASHER	
27	4	32018005	5/16 - 18 HEX NUT	
28	1	1515	#50 CHAIN - 112 LINKS	
29	1	1514	SPROCKET - 20T	
30	1	153620	DRIVE ARM OUTER SHEILD	
31	1	1516	IDLER SPROCKET	
32	1	14011105	5/8-11 UNC X 2.5 HEX BOLT	
33	1	54011005	5/8 - 11 HEX LOCK NUT	

DRIVE ASSEMBLY - OUTSIDE - 5605 DRILL

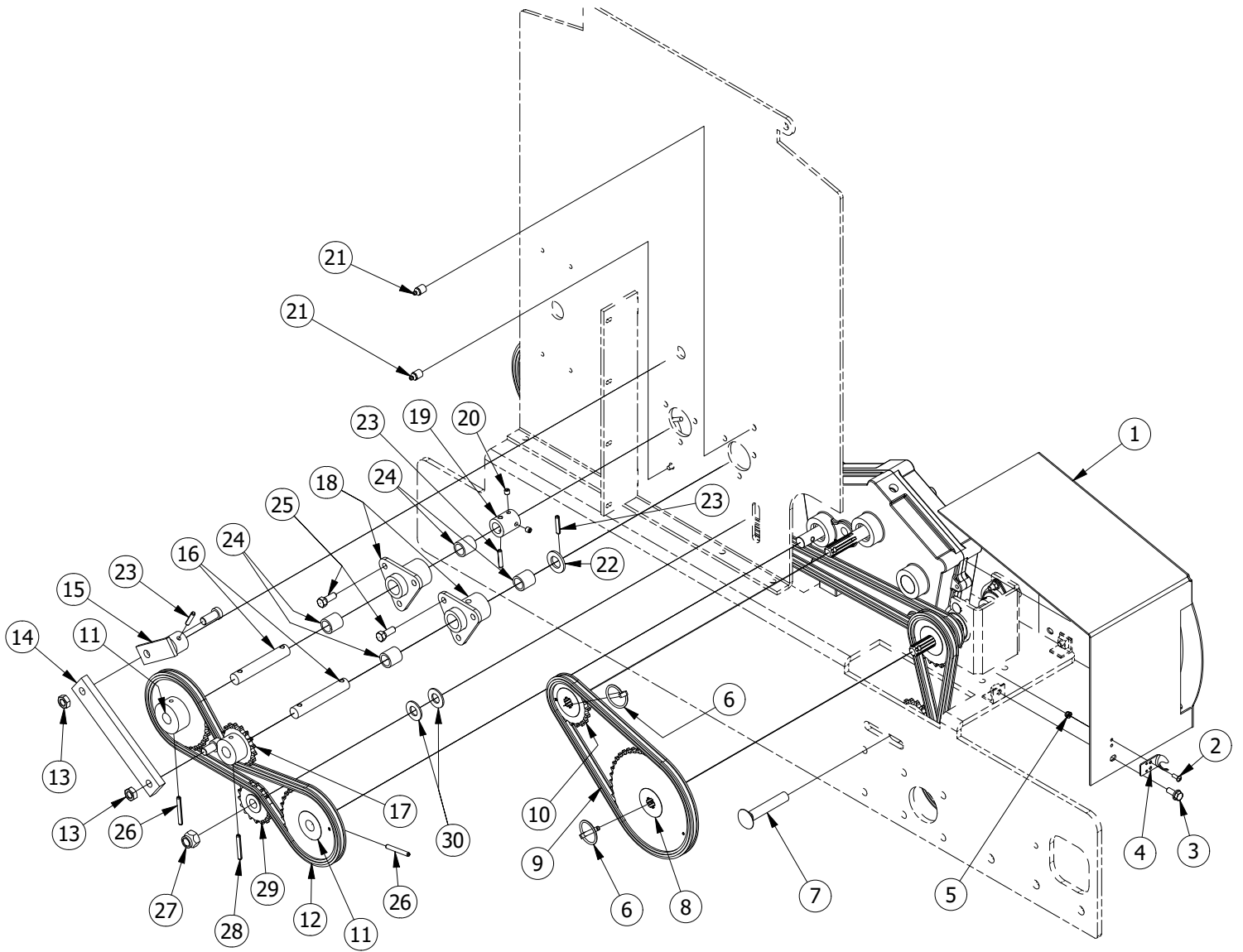

DRIVE ASSEMBLY - OUTSIDE - 5605 DRILL

PARTS LIST				
ITEM	QTY	PART NUMBER	DESCRIPTION	COMMENTS
1	1	140320	GEARBOX SHIELD	
2	2	11024022	10 - 24 X 1/2 PAN HEAD SCREW	
3	3	12018032	5/16-18 X 0.75 FLANGE BOLT	
4	1	1404	HOOD LATCH SUPPORT	
5	2	51024002	No. 10 - 24 HEX LOCK NUT	
6	2	1421	LINCH PIN	
7	1	24011145	5/8-11 X 3.5 CARRIAGE BOLT	
8	1	1419	SPROCKET - 45T	
9	1	1420	#40 CHAIN 67 LINKS	
10	1	1418	SPROCKET - 20T	
11	2	1410	SPROCKET - 32T	
12	1	1426	#40 CHAIN 84 LINKS	
13	2	53213002	1/2 - 13 HEX JAM NUT	
14	1	1407	AGITATOR LINK	
15	1	1406	AGITATOR ARM	
16	2	1412	SEED BOX JACK SHAFT	
17	1	1408	SPROCKET - 17T	
18	2	141620	TRIANGLE HUB	
19	1	1411	SQUARE COUPLER	
20	2	1414	5/16-18 X 0.31	
21	2	Z18FP	ZERK	
22	4	84800000	3/4 SAE WASHER	
23	4	93160500	1/4 x 1 1/4 ROLL PIN	
24	6	1415	BRONZE BUSHING	
25	8	12416045	3/8-16 UNC X 1 HEX BOLT	
26	5	93160800	1/4 x 2 ROLL PIN	
27	3	54011005	5/8 - 11 HEX LOCK NUT	
28	2	93160700	1/4 x 1 3/4 ROLL PIN	
29	3	1409	IDLER SPROCKET	
30	5	84000000	5/8 SAE WASHER	

DRIVE ASSEMBLY - INSIDE - 5605 DRILL

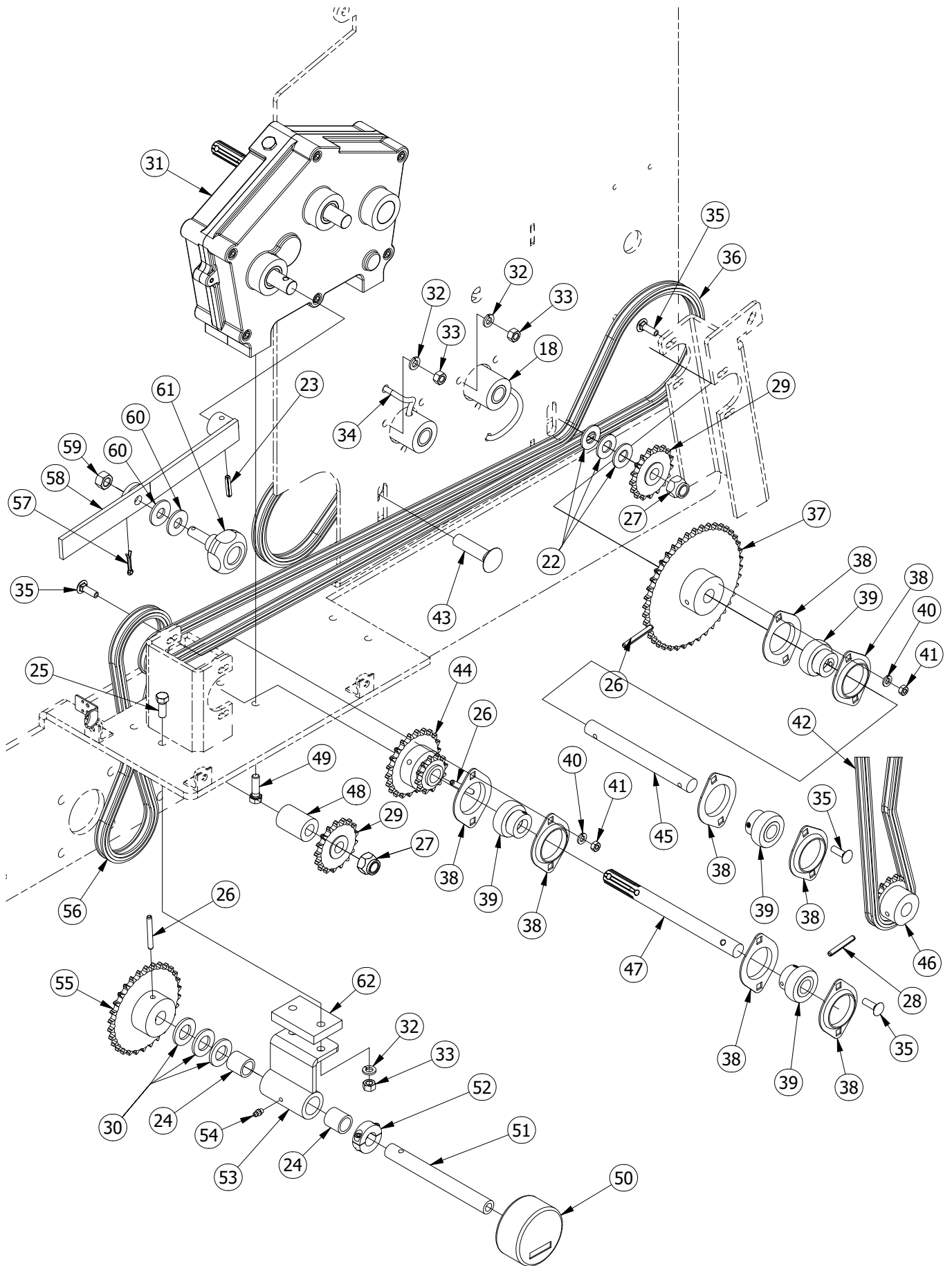

DRIVE ASSEMBLY - INSIDE - 5605 DRILL

PARTS LIST				
ITEM	QTY	PART NUMBER	DESCRIPTION	COMMENTS
22	4	84800000	3/4 SAE WASHER	
23	4	93160500	1/4 x 1 1/4 ROLL PIN	
24	6	1415	BRONZE BUSHING	
25	2	12416065	3/8-16 UNC X 1-1/2 HEX BOLT	
26	5	93160800	1/4 x 2 ROLL PIN	
27	3	54011005	5/8 - 11 HEX LOCK NUT	
28	2	93160700	1/4 x 1 3/4 ROLL PIN	
29	3	1409	IDLER SPROCKET	
30	5	84000000	5/8 SAE WASHER	
31	1	1401	GEARBOX	
32	12	62400000	3/8 LOCK WASHER	
33	8	32416005	3/8 - 16 HEX NUT	
34	2	1417	GREASE HOSE	
35	8	22018042	5/16-18 X 1 CARRIAGE BOLT	
36	1	1439	#40 CHAIN 172 LINKS	
37	1	1435	SPROCKET - 42T	
38	8	1424	BEARING FLANGE	
39	4	1423	BEARING	
40	8	62000000	5/16 LOCK WASHER	
41	8	31620005	5/16 - 18 HEX NUT	
42	1	1443	#40 CHAIN 69 LINKS	
43	2	24011105	5/8-11 X 2.5 CARRIAGE BOLT	
44	1	1425	SPROCKET - 22T, 12T	
45	1	1436	SHAFT	
46	1	1437	SPROCKET - 16T	
47	1	1422	SPLINE SHAFT	
48	1	1428	SPACER	
49	4	12416055	3/8-16 UNC X 1.25 HEX BOLT	
50	1	1431	ACRE METER	
51	1	1430	ACRE METER SHAFT	
52	2	1433	SHAFT COLLAR	
53	1	143220	SUPPORT	
54	1	Z1428	ZERK	
55	1	1445	SPROCKET - 34T	
56	1	1434	#40 CHAIN 67 LINKS	
57	1	91100400	5/32 x 1 COTTER PIN	
58	1	1402	GEARBOX LEVER	
59	1	33213005	1/2 - 13 HEX NUT	
60	2	73200000	1/2 WASHER	
61	1	1405	KNOB	
62	1	1429	METER SUPPORT SPACER	

GEARBOX - 5605 DRILL

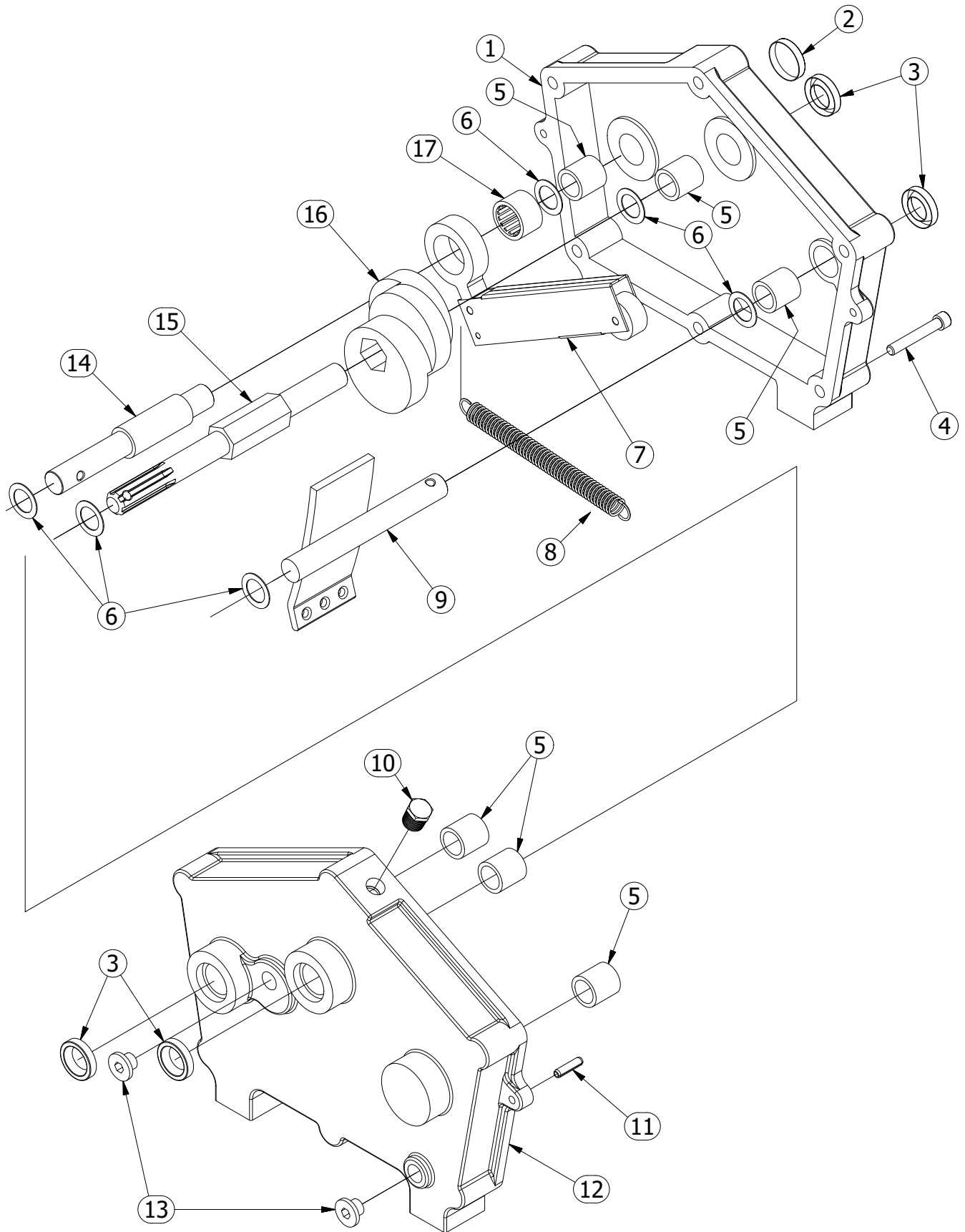

GEARBOX - 5605 DRILL

PARTS LIST				
ITEM	QTY	PART #	DESCRIPTION	COMMENTS
1	1	1301	GEARBOX LEFT CASTING	INCLUDES #1310, 1311, 1415
2	1	1311	CAP	
3	4	1310	SEAL	
4	6	1312	SOCKET HEAD BOLT	
5	6	1415	BRONZE BUSHING	
6	6	1316	SHIM WASHER	
7	3	1306	GEARBOX ARM	
8	3	1309	SPRING	
9	1	1303	CAM GUIDE	
10	1	1315	BREATHER PLUG	
11	2	93160400	ROLL PIN	
12	1	1302	GEARBOX RIGHT CASTING	INCLUDES #1310, 1415
13	2	1314	PLUG	
14	1	1308	SHAFT	
15	1	1304	SHAFT	
16	1	1305	GEARBOX CAM	
17	3	1307	CLUTCH BEARING	

SEED BOX ASSEMBLY - 5605 DRILL

PARTS LIST				
ITEM	QTY	PART NUMBER	DESCRIPTION	COMMENTS
1	1	123220	SEED BOX LID	
2	2	13213075	1/2-13 UNC X 1.75 HEX BOLT	
3	2	1658	BUSHING	
4	2	73200000	1/2 WASHER	
5	2	53213005	1/2 - 13 HEX LOCK NUT	
6	2	91100400	5/32 x 1 COTTER PIN	
7	1	72800000	7/16 WASHER	
8	1	1238	LID GUIDE	
9	1	123120	SEED BOX	
10	8	12416055	3/8-16 UNC X 1.25 HEX BOLT	
11	2	12018035	5/16-18 UNC X 0.75 HEX BOLT	
12	12	62400000	3/8 LOCK WASHER	
13	12	32416005	3/8 - 16 HEX NUT	
14	1	1220	MANUAL HOLDER	
15	2	41818005	5/16 - 18 HEX FLANGE NUT	
16	1	123520	REAR SHEILD REMOVABLE	
17	1	123420	REAR SHIELD	
18	2	11620035	1/4-20 UNC X 0.75 HEX BOLT	
19	1	1233	FRONT SHIELD	
20	13	41620005	1/4 - 20 HEX FLANGE NUT	
21	4	21620032	1/4-20 X 0.75 CARRIAGE BOLT	
22	1	120820	COVER	
23	4	12416045	3/8-16 UNC X 1 HEX BOLT	
24	12	83600000	9/16 SAE WASHER	
25	12	1212	SPRING	
26	12	1210	FOAM PLATE	
27	12	1211	FOAM	
28	12	1209	SEED CHUTE	
29	1	1236	SEED BOX DRIVE SHAFT	
30	1	121720	HINGE	
31	2	51024002	No. 10 - 24 HEX LOCK NUT	
32	1	1219	HOOD LATCH	
33	2	11024022	10 - 24 X 1/2 PAN HEAD SCREW	
34	1	121820	GEARBOX SHIELD	
35	4	21620022	1/4-20 X 0.5 CARRIAGE BOLT	
36	3	11620045	1/4-20 UNC X 1 HEX BOLT	
37	3	1207	WING NUT	
38	1	1237	AGITATOR SHAFT - 5 FT DRILL	
39	12	1216	AGITATOR CLIP	
40	3	1214	BUSHING	

SMALL SEED BOX - 5605 DRILL

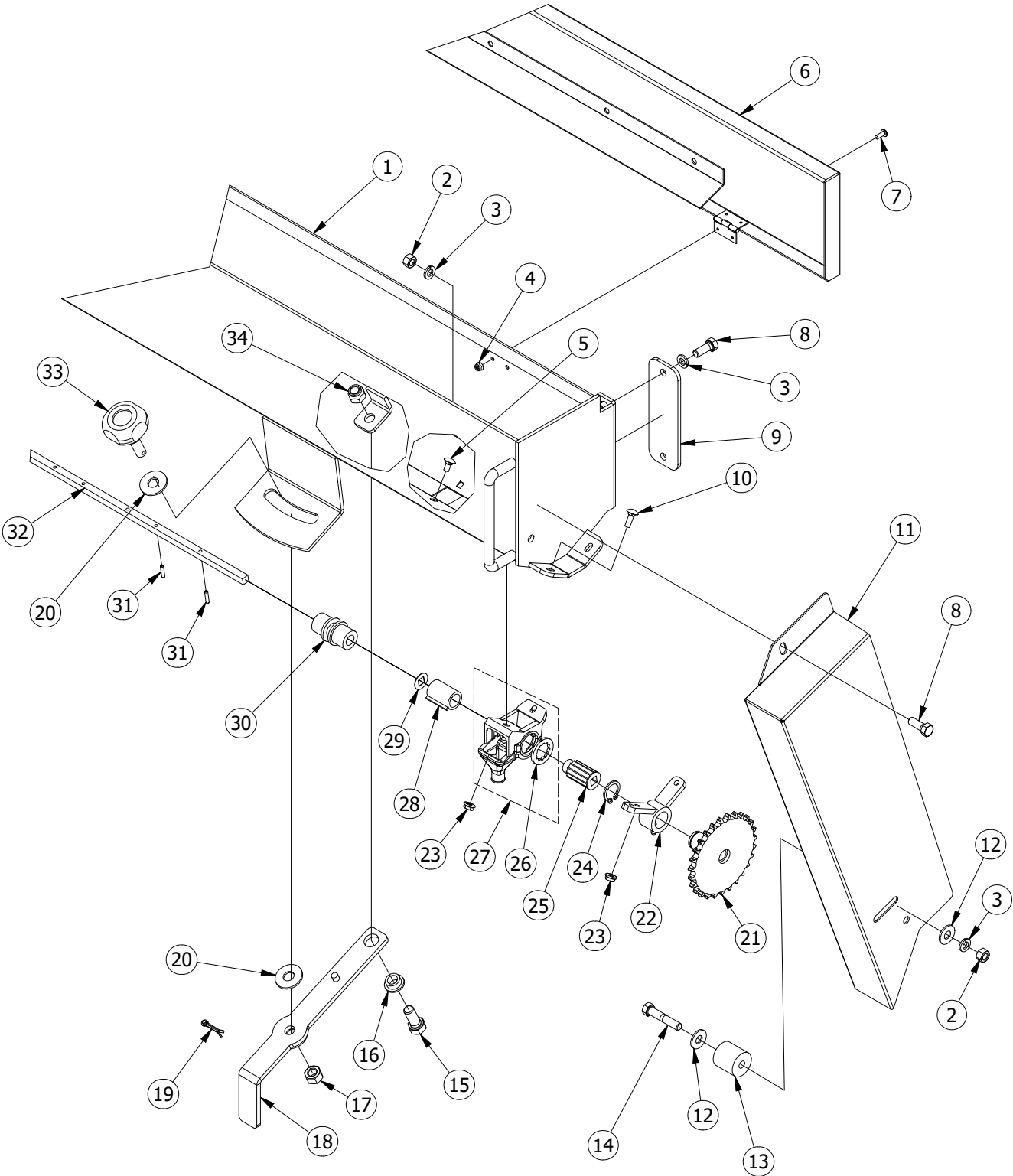

SMALL SEED BOX - 5605 DRILL

PARTS LIST				
ITEM	QTY	PART NUMBER	DESCRIPTION	COMMENTS
1	1	193120	SEED BOX	
2	2	32416005	3/8 - 16 HEX NUT	
3	6	62400000	3/8 LOCK WASHER	
4	4	51024002	No. 10 - 24 HEX LOCK NUT	
5	24	21620022	1/4-20 X 0.5 CARRIAGE BOLT	
6	1	193220	LID	
7	4	11024022	10 - 24 X 1/2 PAN HEAD SCREW	
8	5	12416045	3/8-16 UNC X 1 HEX BOLT	
9	2	190020	SMALL SEED BOX SUPPORT	
10	2	21620032	1/4-20 X 0.75 CARRIAGE BOLT	
11	1	193420	SMALL SEED BOX SHIELD - 3 FT AND 5 FT	
12	2	72400000	3/8 WASHER	
13	1	1915	CHAIN TIGHTNER	
14	1	12416085	3/8-16 UNC X 2 HEX BOLT	
15	1	13213055	1/2-13 UNC X 1.25 HEX BOLT	
16	1	1916	SMALL SEED BOX LEVER BUSHING	
17	1	33213005	1/2 - 13 HEX NUT	
18	1	1910	SMALL BOX LEVER	
19	1	91100400	5/32 x 1 COTTER PIN	
20	2	73200000	1/2 WASHER	
21	1	1912	SPROCKET 27T	
22	1	1911	BEARING	
23	26	41620005	1/4 - 20 HEX FLANGE NUT	
24	1	1913	EXTERNAL RETAINING RINGS	
25	12	1906	SEED SPROCKET	
26	12	1905	SEED WASHER	
27	12	1904	SEED CUP	
28	12	1907	SLEEVE	
29	12	1908	WASHER	
30	1	1909	ADJUSTMENT COLLAR	
31	24	93100300	ROLL PIN	
32	1	1933	SMALL SEED BOX SHAFT	
33	1	1405	KNOB	
34	1	53213005	1/2 - 13 HEX LOCK NUT	

COULTER UNIT - 5605 DRILL

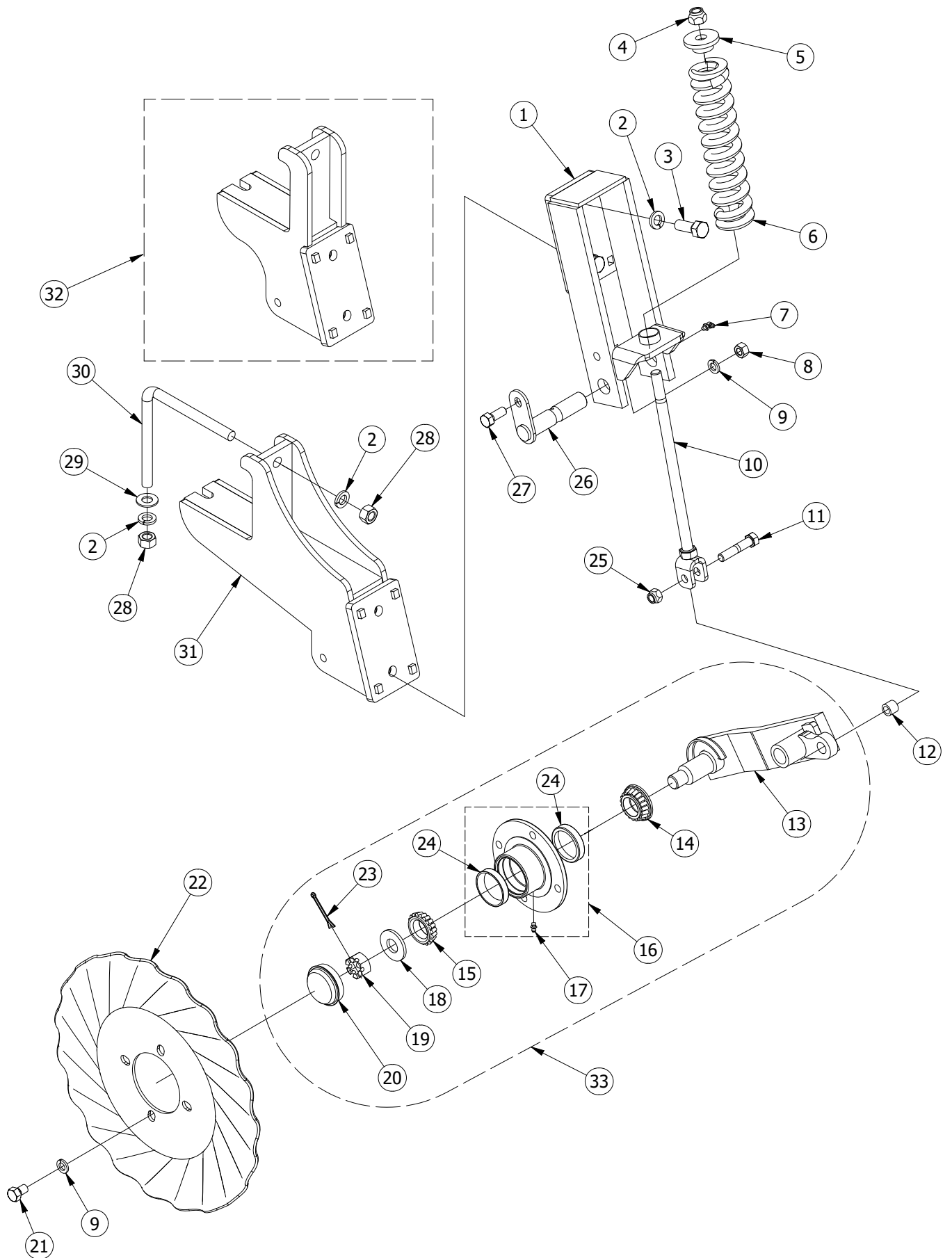

COULTER UNIT - 5605 DRILL

PARTS LIST				
ITEM	QTY	PART NUMBER	DESCRIPTION	COMMENTS
1	12	165320	COULTER ARM MOUNT	
2	48	64000000	5/8 LOCK WASHER	
3	24	14011075	5/8-11 UNC X 1.75 HEX BOLT	
4	12	54011005	5/8 - 11 HEX LOCK NUT	
5	12	1655	COULTER SPRING CAP	
6	12	1656	COULTER SPRING	
7	12	Z1490	ZERK , 90 deg	
8	12	33213005	1/2 - 13 HEX NUT	
9	60	63200000	1/2 LOCK WASHER	
10	12	1657	COULTER SPRING BOLT	
11	12	13213108	1/2-13 UNC X 2.5 HEX BOLT	
12	12	1658	WEAR BUSHING	
13	12	165920	COULTER ARM	
14	12	1660	BEARING WITH SEAL	
15	12	1661	BEARING	
16	12	166520	COULTER HUB	INCLUDES 1662, Z1428
17	6	Z1428	ZERK	
18	12	1667	COULTER SPINDLE WASHER	
19	12	1663	7/8 - 14 SLOTTED HEX NUT	
20	12	166420	HUB CAP	
21	48	13220035	1/2-20 UNF X 0.75 HEX BOLT	
22	12	1666	COULTER BLADE	
23	12	91100800	5/32 x 2 COTTER PIN	
24	24	1662	BEARING CUP	
25	12	53213005	1/2 - 13 HEX LOCK NUT	
26	12	165420	COULTER ARM PIN	
27	12	13213055	1/2-13 UNC X 1.25 HEX BOLT	
28	24	34011005	5/8 - 11 HEX NUT	
29	12	84000000	5/8 SAE WASHER	
30	12	1652	L BOLT	
31	6	165020	LONG MOUNTING BRACKET	
32	6	165120	SHORT MOUNTING BRACKET	
33	12	166920	COULTER ARM ASSEMBLY	

DISC UNIT - 5605 DRILL

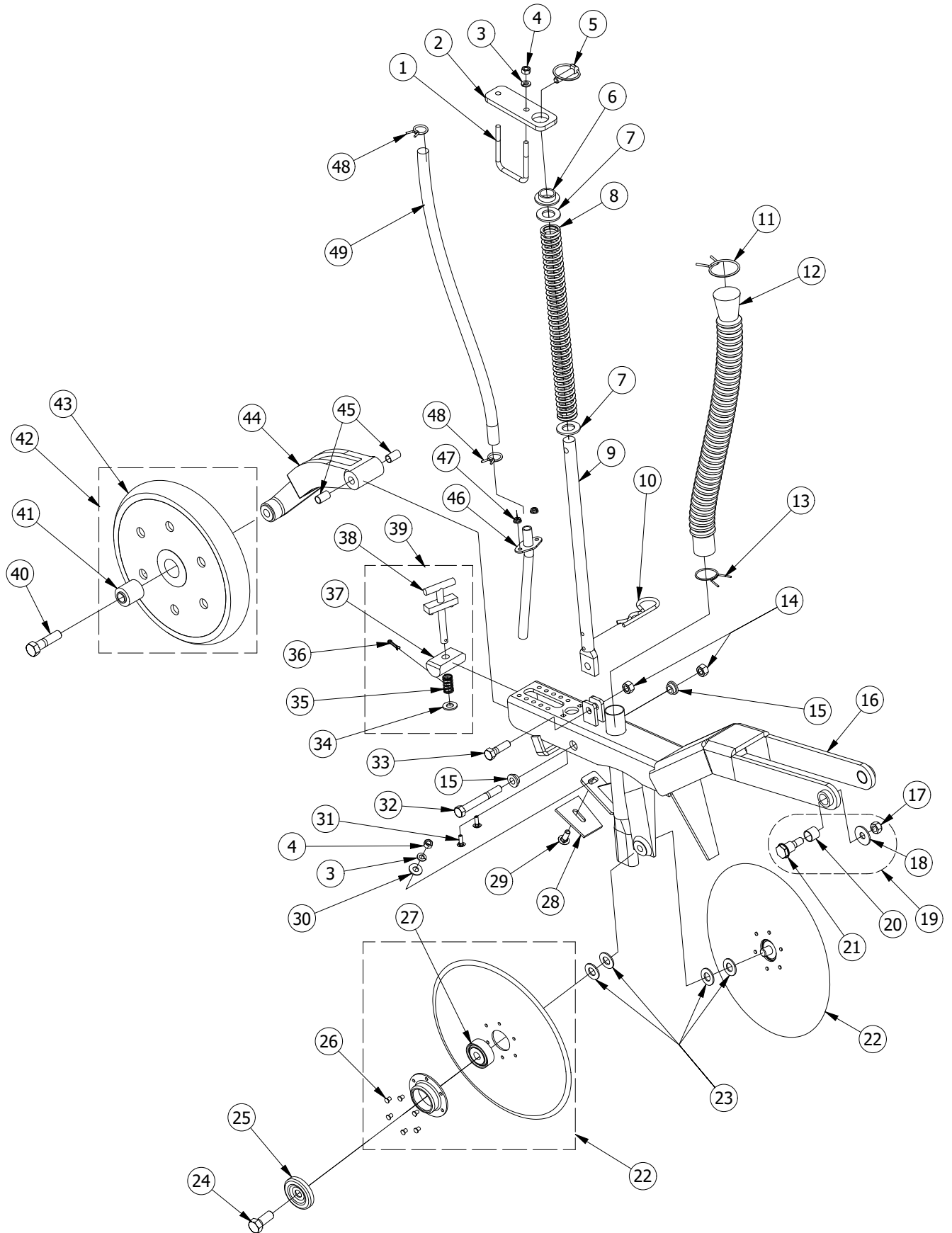

DISC UNIT - 5605 DRILL

PARTS LIST				
ITEM	QTY	PART #	DESCRIPTION	COMMENTS
1	12	1623	U BOLT	
2	12	162220	ROD PLATE	
3	36	62400000	3/8 LOCK WASHER	
4	36	32416005	3/8 - 16 HEX NUT	
5	12	1620	LINCH PIN	
6	12	1621	BUSHING	
7	24	85600000	7/8 SAE WASHER	
8	12	1619	SPRING	
9	12	161720	SPRING ROD	
10	12	1618	HAIRPIN	
11	12	1626	TOP HOSE CLAMP	
12	12	1625	HOSE	
13	12	1624	BOTTOM HOSE CLAMP	
14	24	53213006	1/2 - 13 REV LOCK NUT	
15	24	1608	BUSHING	
16	12	160320	DOUBLE DISC ARM	
17	24	53220008	STOVER LOCK NUT	
18	24	1600	SPRING WASHER	
19	12	1645	WEAR BOLT KIT	
20	24	1642	DISC ARM BUSHING	
21	24	1641	SHOULDER BOLT	
22	24	1605	DISC BLADE	
23	48	84000000	5/8 SAE WASHER	
24	24	14011065	5/8-11 UNC X 1.5 HEX BOLT	
25	24	1604	DUST CAP	
26	24	1627	BOLT KIT	
27	24	1606	BEARING	
28	12	1607	SCRAPER	
29	12	22416042	3/8-16 X 1 CARRIAGE BOLT	
30	12	72400000	3/8 WASHER	
31	24	21620032	1/4-20 X 0.75 CARRIAGE BOLT	
32	12	13213168	1/2-13 UNC X 4 HEX BOLT	
33	12	13213075	1/2-13 UNC X 1.75 HEX BOLT	
34	12	83200000	1/2 SAE WASHER	
35	12	1613	SPRING	
36	12	91100400	5/32 x 1 COTTER PIN	
37	12	1612	DEPTH BLOCK	
38	12	1611	T HANDLE	
39	12	1628	T HANDLE ASSEMBLY	
40	12	14011105	5/8-11 UNC X 2.5 HEX BOLT	
41	12	1630	PRESS WHEEL BEARING	
42	12	1610	PRESS WHEEL	
43	12	1631	PRESS WHEEL TIRE	
44	12	160920	PACKER WHEEL ARM	
45	24	1640	PACKER ARM BUSHING	
46	12	161420	SEED TUBE	
47	24	41620005	1/4 - 20 HEX FLANGE NUT	
48	24	1616	SMALL HOSE CLAMP	
49	12	1615	SEED HOSE	

HYDRAULICS - 5605 DRILL

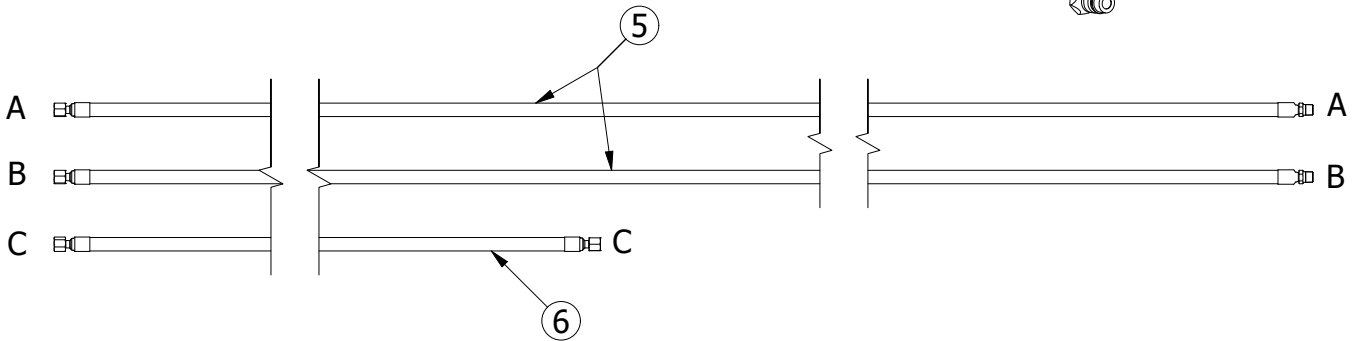
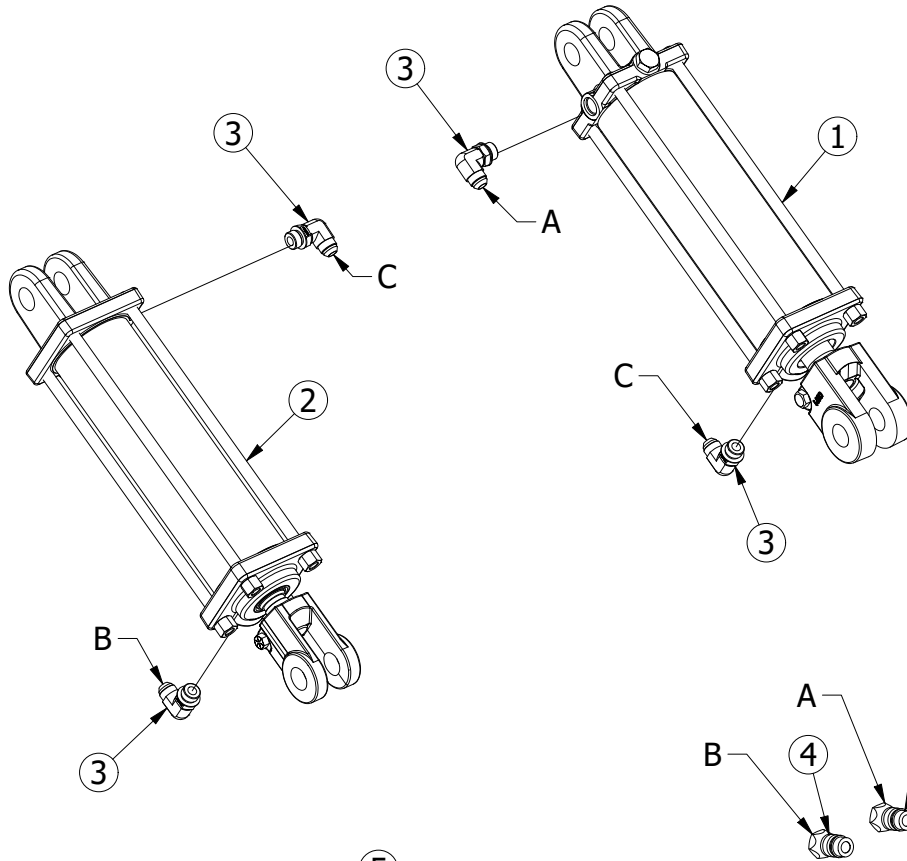

PARTS LIST			
ITEM	QTY	PART NUMBER	DESCRIPTION
1	1	1106	HYDRAULIC CYLINDER
2	1	1107	HYDRAULIC CYLINDER
3	4	680188	ADAPTER
4	2	1012	MALE QUICK COUPLER
5	2	1002	HYDRAULIC HOSE
6	1	1001	HYDRAULIC HOSE

DECALS - 5605 DRILL

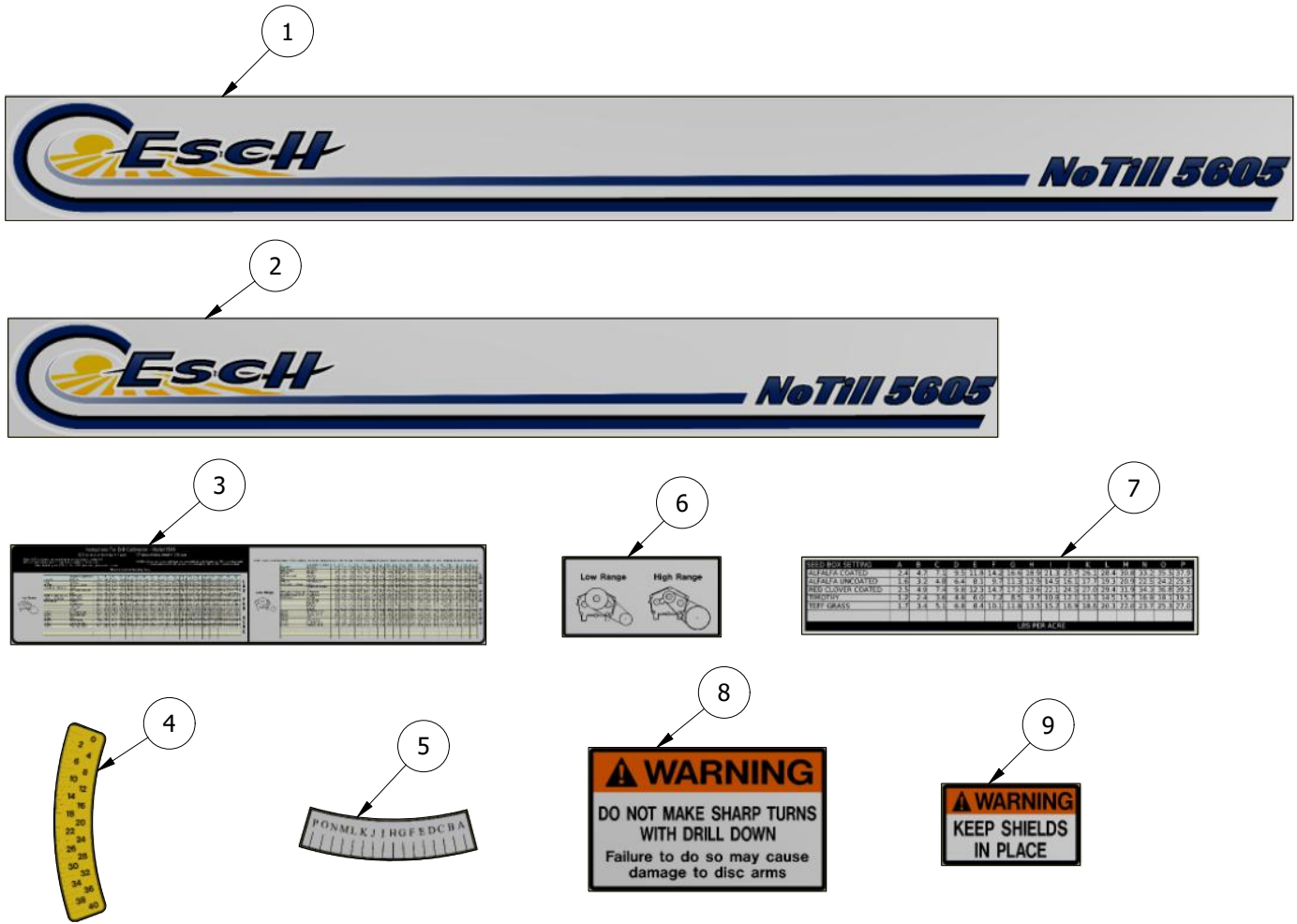

PARTS LIST				
ITEM	QTY	PART #	DESCRIPTION	COMMENTS
1	1	181520	5605 - FRONT LOGO DECAL	
2	1	181620	5605 - REAR LOGO DECAL	
3	1	181720	5605 - SEED CHART	
4	1	1801	NUMBER GAUGE DECAL	
5	1	1802	LETTER GAUGE DECAL	
6	1	1803	GEARBOX RANGE DECAL	
7	1	1809	SMALL SEED BOX CHART	
8	1	1804	WARNING SHARP TURN DECAL	
9	2	1805	WARNING SHIELDS DECAL	