

ESCH 5612 DRILL

Operator's Manual and Parts List



Swing Instructions

- Keep drill on a level area when swinging.
- Do not engage tractor brake when swinging.
- Always keep black knob on hydraulic manifold in normal operation mode (counter clockwise).
- If valve is rotated clockwise to tongue swing mode, the transport wheels will not move, only the tongue will move.

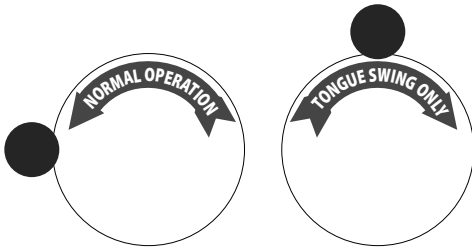
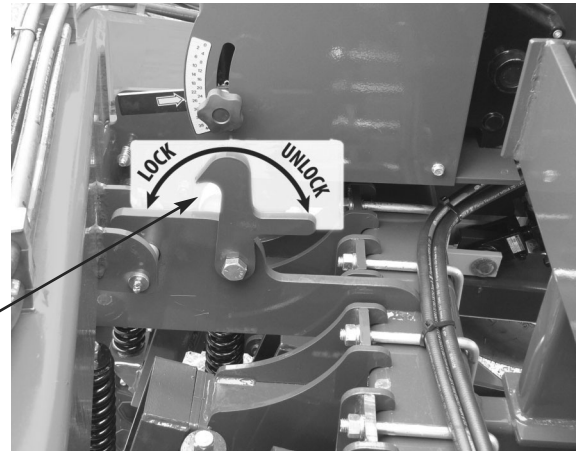
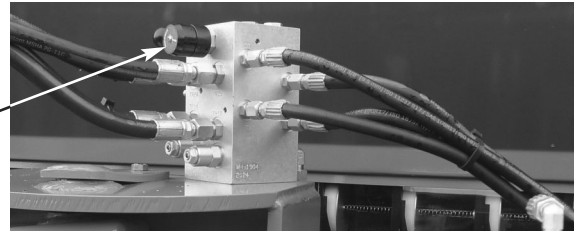

Safety Lock
Keep in locked position when transporting



Transport Wheels

Planting Wheels

To Swing from Transport to Field Mode

#1 - Lower field wheels

#2 - Lower the drill

The valve on drill will automatically switch to the tongue swing and back to transport wheels.

The tongue will swing when field wheels touch the ground.

After tongue is in field mode the transport wheels will lift from the ground.

To Swing from Field to Transport Mode

#1 - Raise drill on field wheels

#2 - Lower transport wheels

The tongue swing will start moving when transport wheels touch the ground.

Seed Calibrations and Settings

- Remove plastic from frame (see Fig. A).
- Place plastic under drill to collect seeds for calibration (see Fig. B).
- See seed chart on lid for further instructions. Note: Be sure to turn drive wheel the correct direction. **WARNING: turning drive wheel too fast will result in wrong calibration. Turn wheel at ground speed.**
- When placing seed in hopper, keep seed baffles down (see Fig.C).
- Keep baffles in up position when seeding fluffy seed.

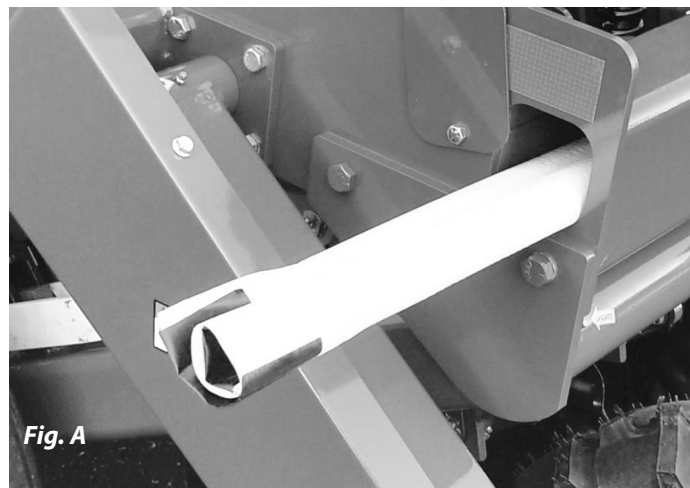

Fig. A



Fig. B



Fig. C

Setting Seeding Depth

- No-till coulters depth can only be set by lowering and raising drill.
- Set no-till coulters approximately 1/2" to 1" deeper than seeding depth.
- Seeding depth can be adjusted by sliding T-handle forward for shallow and backward for deeper.

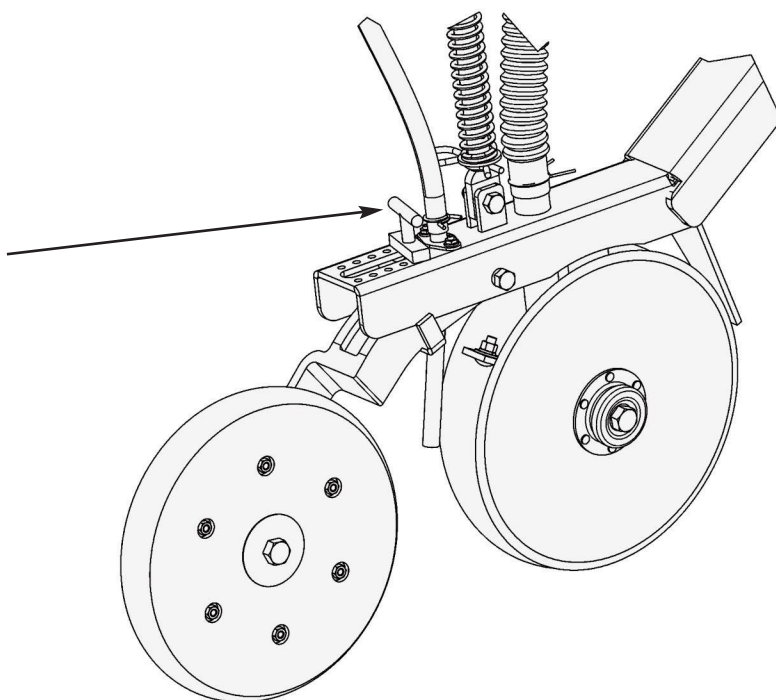

Safety

- Do not ride on drill while moving.
- Do not make sharp turns while drill is down.
- Raise drill when going over rocks that are above ground.

Storage

- Do not store in area where there are lots of mice. Mice like to chew the foams if they can get in the seed box.

Maintenance

- Grease coulters arms: **(A)**
every 10 hours.
- Grease coulters hubs: **(B)**
every 50 hours.
- Grease all other zerks:
every 20 hours.

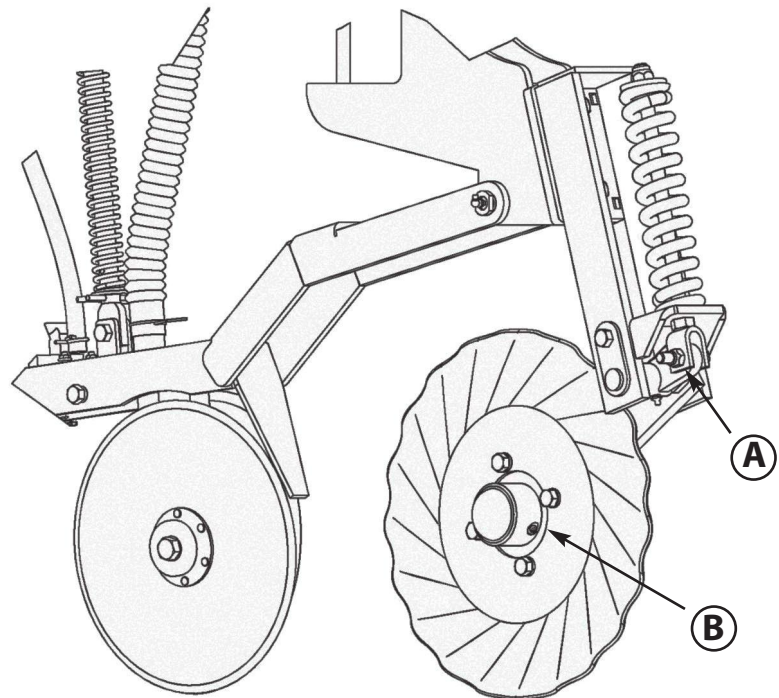

Replacing Foams

- Remove shield on back side of drill (wing nuts).
- Remove shield on left side of seed box.
- Loosen set screws where square shaft slides into round coupler.
- Now shaft is ready to pull out.
- Foam can be cut from plate with a sharp knife or razor.
- Set foams and plate on a piece of card board.
- Spray foams and plates with a spray adhesive.
- Leave set for approximately 1 minute before setting foam on plate.

Trouble Shooting

1 - Seed flows faster on one row:

Foam may be torn or mouse may have chewed a hole in the foam.

2 - One side of drill is lower than other side:

Raise drill the whole way up to realign.

FRAME ASSEMBLY - DRILL 5612

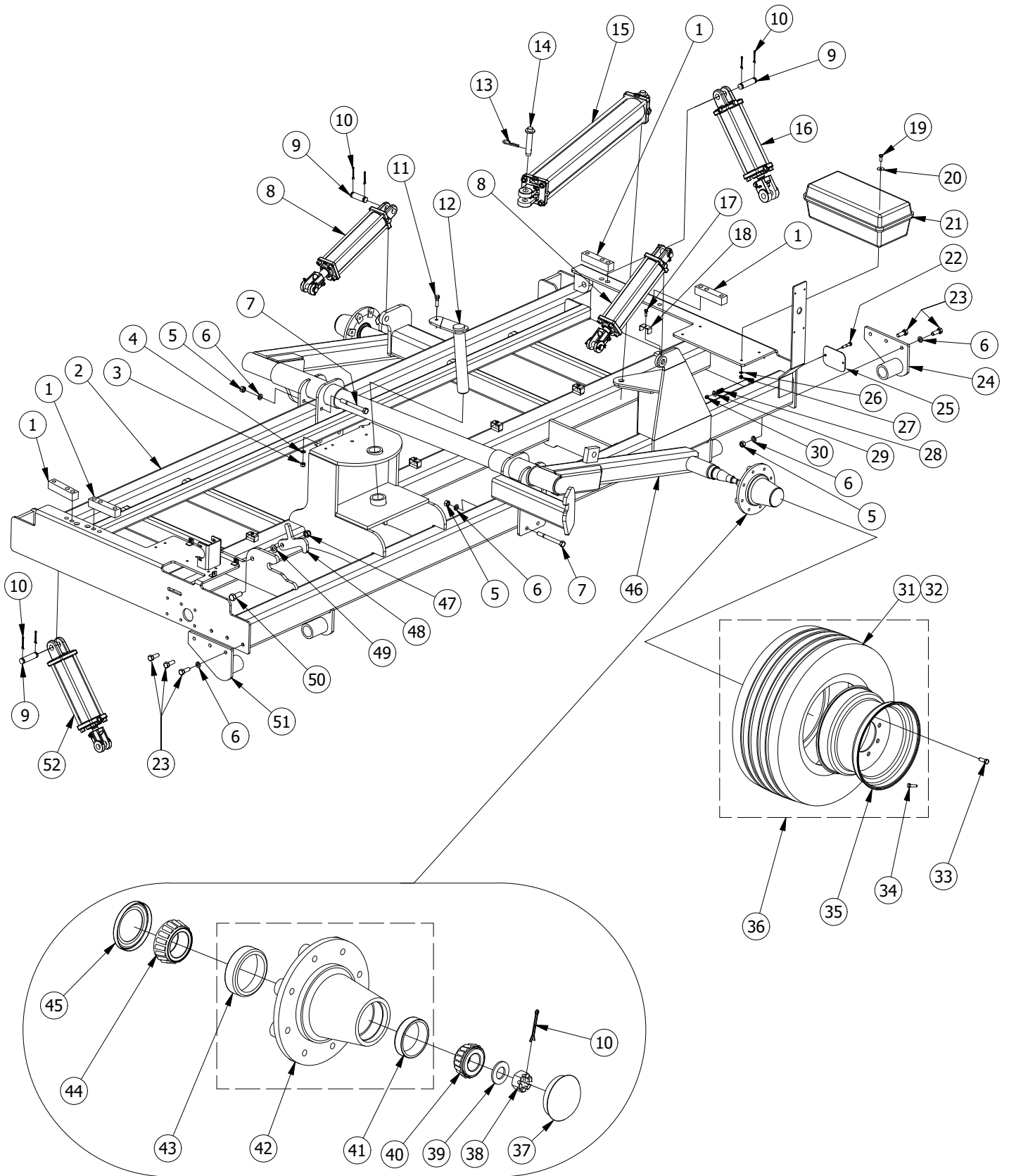

FRAME ASSEMBLY - DRILL 5612

PARTS LIST				
ITEM	QTY	PART NUMBER	DESCRIPTION	COMMENTS
1	4	113820	WEIGH BAR REPLACEMENT BLOCK	
2	1	113920	FRAME - 12 FT DRILL	
3	1	33213005	1/2 - 13 HEX NUT	
4	1	63200000	1/2 LOCK WASHER	
5	12	34011005	5/8 - 11 HEX NUT	
6	14	64000000	5/8 LOCK WASHER	
7	8	14011245	5/8-11 UNC X 6 HEX BOLT	
8	2	1147	HYD CYL 3 X 12	SEAL KIT - 1147K
9	6	1124	PIN	
10	14	91100800	5/32 x 2 COTTER PIN	
11	1	13213075	1/2-13 UNC X 1.75 HEX BOLT	
12	1	114220	PIN ASSEMBLY	
13	2	1150	1" CYLINDER PIN CLIP	
14	2	114920	1" HITCH PIN	
15	1	114620	HYD CYL 4 X 36	SEAL KIT - 104620K
16	1	1127	HYDRAULIC CYLINDER	SEAL KIT - 1127K
17	6	12018045	5/16-18 UNC X 1 HEX BOLT	
18	6	1075	HOSE CLIP	
19	4	12416045	3/8-16 UNC X 1 HEX BOLT	
20	4	72405000	FENDER WASHER	
21	1	1115	TOOL BOX	
22	1	12416085	3/8-16 UNC X 2 HEX BOLT	
23	6	14011075	5/8-11 UNC X 1.75 HEX BOLT	
24	1	110820	SUPPORT - LEFT	
25	1	112320	TARP COVER	
26	4	62400000	3/8 LOCK WASHER	
27	4	32416005	3/8 - 16 HEX NUT	
28	1	1613	SPRING	
29	1	72400000	3/8 WASHER	
30	1	52416005	3/8 - 16 HEX LOCK NUT	
31	2	1189	RADIAL TIRE	
32	1	1186	INNER TUBE	
33	16	1180	LUG BOLT	
34	2	1190	VALVE STEM	
35	2	118520	RIM	
36	1	1188	RADIAL WHEEL ASSEMBLY	
37	2	109320	HUB CAP	
38	2	1663	7/8 - 14 SLOTTED HEX NUT	
39	2	85600000	7/8 SAE WASHER	
40	2	1094	BEARING	
41	2	1095	BEARING CUP	
42	2	109620	WHEEL HUB	INCLUDES #1095, 1097
43	2	1097	BEARING CUP	
44	2	1098	BEARING	
45	2	1099	WHEEL SEAL	
46	1	119320	LIFT WHEELS - TRANSPORT	
47	1	54809005	3/4 - 10 HEX LOCK NUT	
48	1	1148	TONGUE LATCH	
49	1	84800000	3/4 SAE WASHER	
50	1	14810085	3/4-10 UNC X 2 HEX BOLT	
51	1	110920	SUPPORT RIGHT	
52	1	1106	HYDRAULIC CYLINDER	SEAL KIT - 1106K

TONGUE ASSEMBLY - DRILL 5612

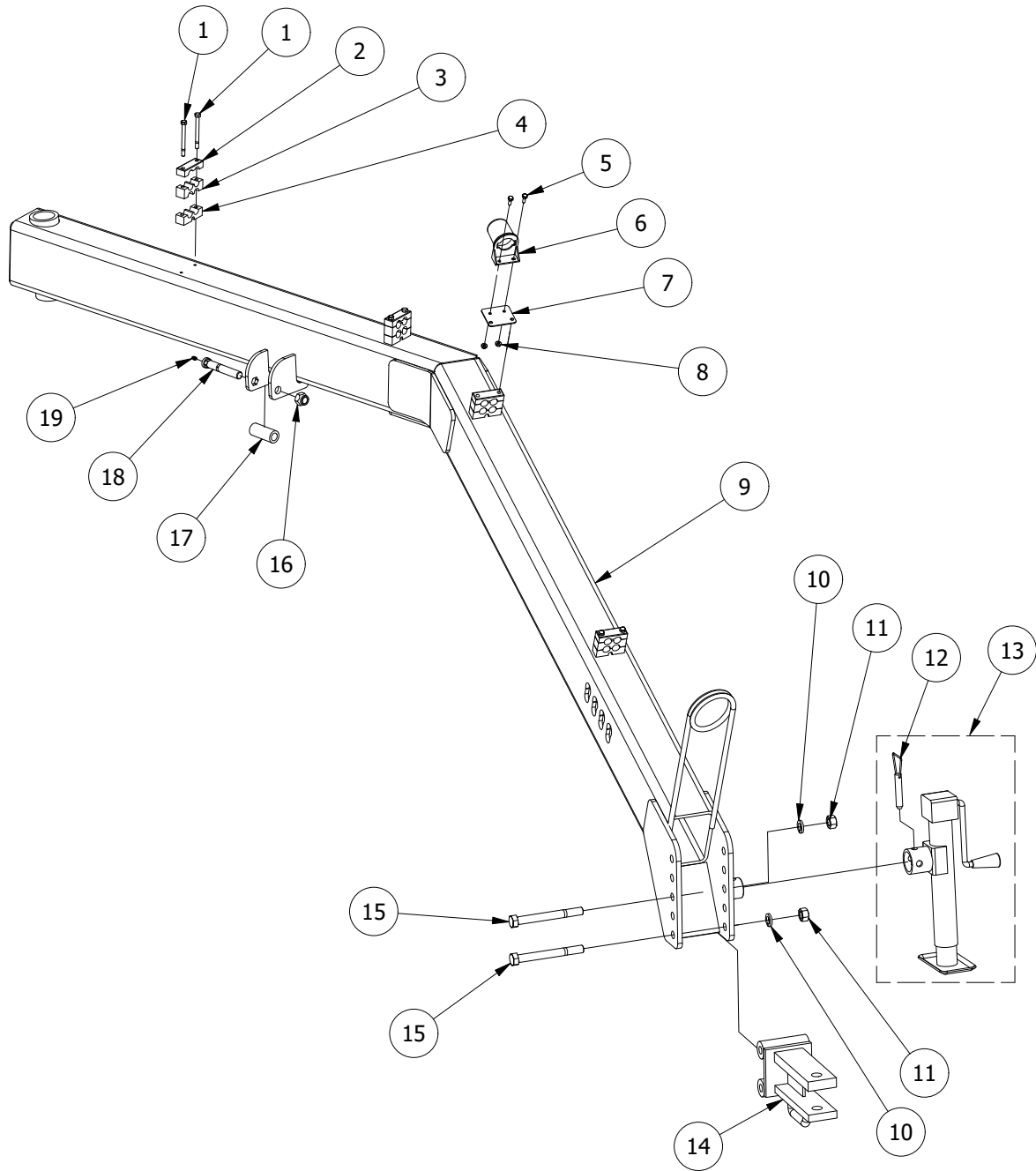

TONGUE ASSEMBLY - DRILL 5612

PARTS LIST				
ITEM	QTY	PART NUMBER	DESCRIPTION	COMMENTS
1	8	12018145	5/16-18 UNC X 3.5 HEX BOLT	
2	4	1077	HOSE BLOCK - TOP	
3	4	1078	HOSE BLOCK - MIDDLE	
4	4	1076	HOSE BLOCK - BOTTOM	
5	2	11620035	1/4-20 UNC X 0.75 HEX BOLT	
6	1	1700	PLUG PROTECTIVE SOCKET	
7	1	119822	MOUNT PLATE FOR LIGHT SOCKET	
8	2	41620005	1/4 - 20 HEX FLANGE NUT	
9	1	114320	5512 TONGUE	
10	2	64800000	3/4 LOCK WASHER	
11	2	34810005	3/4 - 10 HEX NUT	
12	1	1102	PIN	
13	1	1101	JACK	
14	1	114420	HITCH	
15	2	14810285	3/4-10 UNC X 7 HEX BOLT	
16	2	54809005	3/4 - 10 HEX LOCK NUT	
17	2	1192	TONGUE SUPPORT ROLLER	
18	2	1191	TONGUE SUPPORT PIN	
19	2	Z1428	ZERK	

STEP ASSEMBLY - DRILL 5612

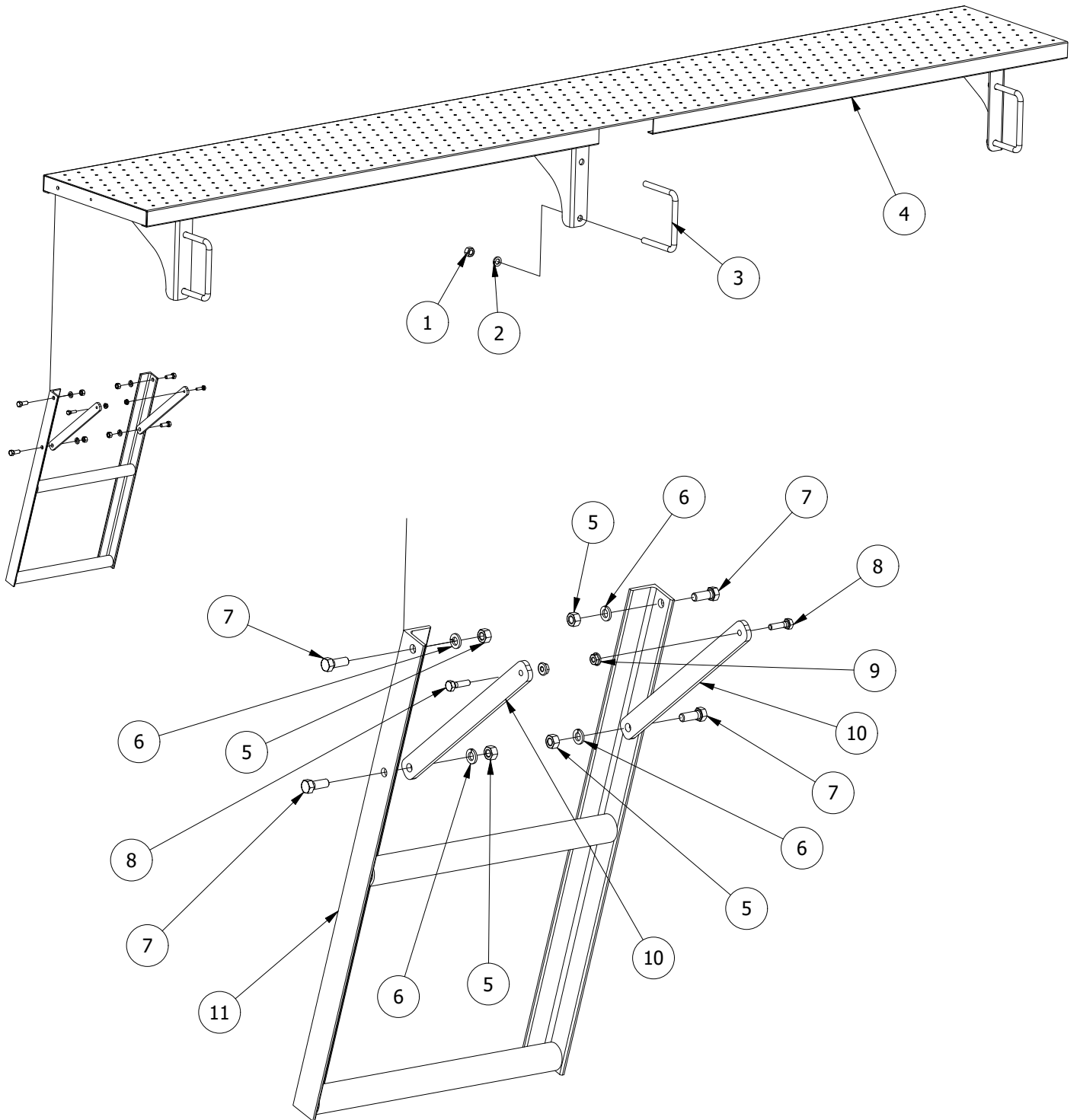

STEP ASSEMBLY - DRILL 5612

PARTS LIST				
ITEM	QTY	PART NUMBER	DESCRIPTION	COMMENTS
1	6	34011005	5/8 - 11 HEX NUT	
2	6	64000000	5/8 LOCK WASHER	
3	3	1118	U BOLT	
4	1	114120	PLATFORM	
5	4	32416005	3/8 - 16 HEX NUT	
6	4	62400000	3/8 LOCK WASHER	
7	4	12416045	3/8-16 UNC X 1 HEX BOLT	
8	2	11620045	1/4-20 UNC X 1 HEX BOLT	
9	2	41620005	1/4 - 20 HEX FLANGE NUT	
10	2	112120	BRACE	
11	1	112020	LADDER	

LIFT WHEELS - 5612 DRILL

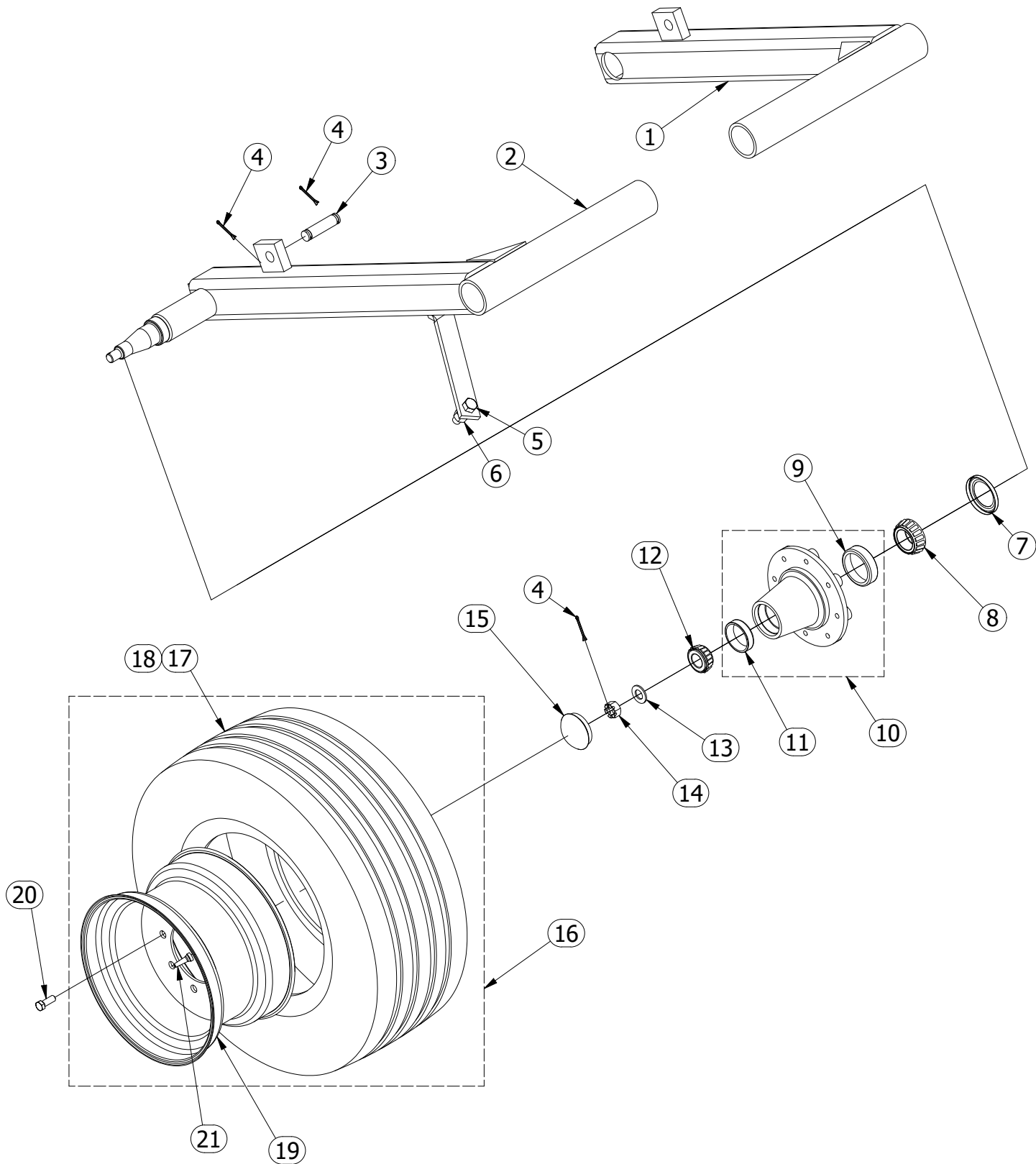

LIFT WHEELS - 5612 DRILL

PARTS LIST				
ITEM	QTY	PART #	DESCRIPTION	COMMENTS
1	1	119620	LEFT LIFT ARM	
2	1	119720	RIGHT LIFT ARM	
3	2	1124	PIN	
4	6	91100800	5/32 x 2 COTTER PIN	
5	1	14810105	3/4-10 UNC X 2.5 HEX BOLT	
6	1	34810005	3/4 - 10 HEX NUT	
7	2	1099	WHEEL SEAL	
8	2	1098	BEARING	
9	2	1097	BEARING CUP	
10	2	109620	WHEEL HUB	INCLUDES #1095, 1097
11	2	1095	BEARING CUP	
12	2	1094	BEARING	
13	2	85600000	7/8 SAE WASHER	
14	2	1663	7/8 - 14 SLOTTED HEX NUT	
15	2	109320	HUB CAP	
16	1	1187	WHEEL ASSEMBLY	INCLUDES 1184, 118520, 1190
17	2	1189	RADIAL TIRE	
18	1	1186	INNER TUBE	
19	2	118520	RIM	
20	16	1180	LUG BOLT	
21	2	1190	VALVE STEM	

DRIVE ARM - 5612 DRILL

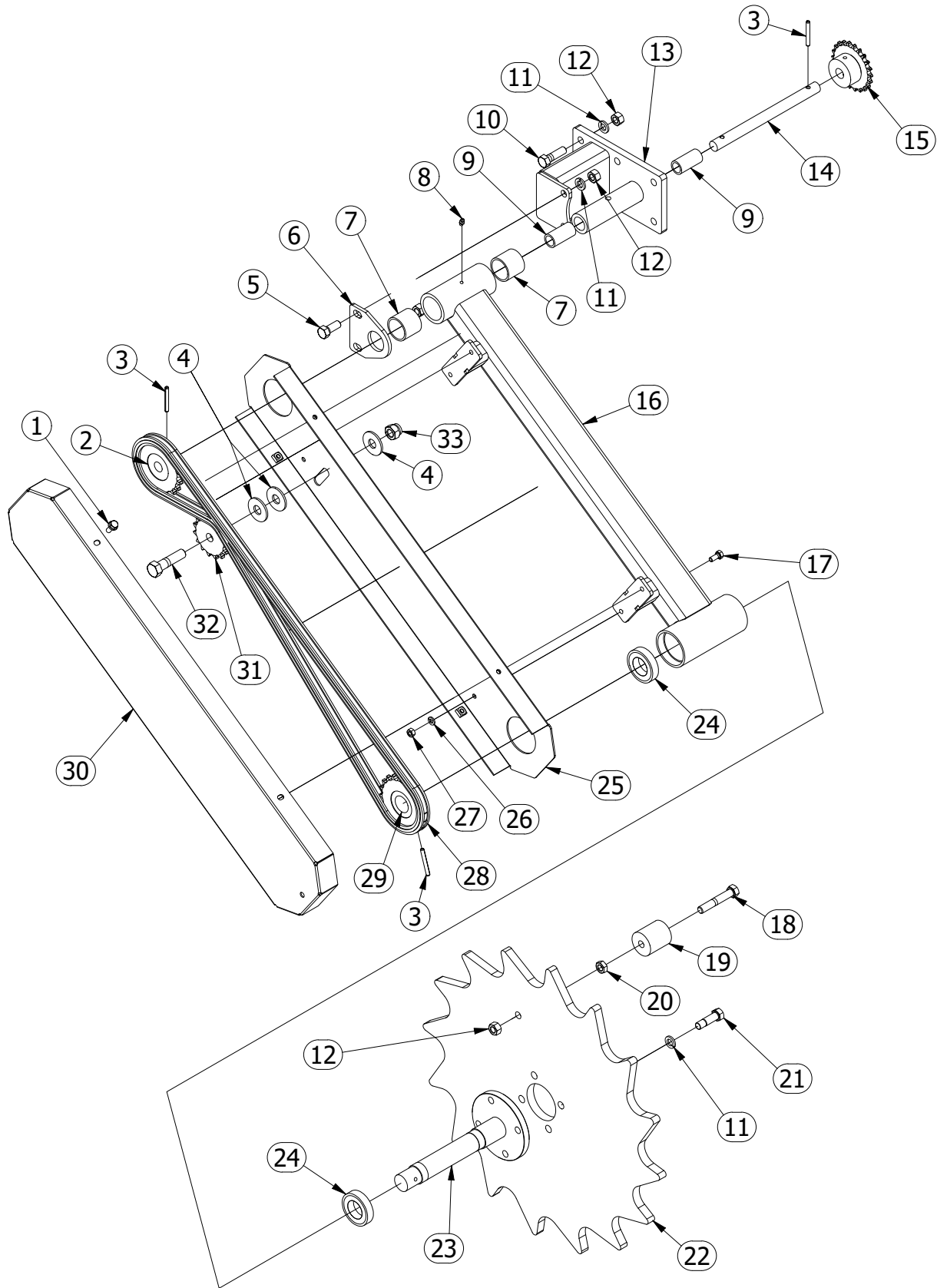

DRIVE ARM - 5612 DRILL

PARTS LIST				
ITEM	QTY	PART #	DESCRIPTION	COMMENTS
1	4	12018032	5/16-18 X 0.75 FLANGE BOLT	
2	1	1517	SPROCKET - 20T	
3	3	93160800	1/4 x 2 ROLL PIN	
4	3	74000000	5/8 WASHER	
5	2	13213055	1/2-13 UNC X 1.25 HEX BOLT	
6	1	150220	SUPPORT	
7	2	1518	BUSHING	
8	1	Z1428	ZERK	
9	2	1519	BUSHING	
10	6	13213075	1/2-13 UNC X 1.75 HEX BOLT	
11	12	63200000	1/2 LOCK WASHER	
12	9	33213005	1/2 - 13 HEX NUT	
13	1	150120	SUPPORT	
14	1	1520	SHAFT	
15	1	1527	SPROCKET - 22T	
16	1	153120	DRIVE WHEEL ARM	
17	4	12018035	5/16-18 UNC X 0.75 HEX BOLT	
18	1	13213128	1/2-13 UNC X 3 HEX BOLT	
19	1	1511	SLEEVE	
20	1	53213002	1/2 - 13 HEX JAM NUT	
21	4	13220075	1/2-20 UNF X 1.75 HEX BOLT	
22	1	1521	STEEL DRIVE WHEEL	
23	1	153220	DRIVE WHEEL SPINDLE	
24	2	153320	BEARING	
25	1	153520	DRIVE ARM INNER SHIELD	
26	4	62000000	5/16 LOCK WASHER	
27	4	32018005	5/16 - 18 HEX NUT	
28	1	1515	#50 CHAIN - 112 LINKS	
29	1	1514	SPROCKET - 20T	
30	1	153620	DRIVE ARM OUTER SHEILD	
31	1	1516	IDLER SPROCKET	
32	1	14011105	5/8-11 UNC X 2.5 HEX BOLT	
33	1	54011005	5/8 - 11 HEX LOCK NUT	

DRIVE ASSEMBLY - OUTSIDE - 5612 DRILL

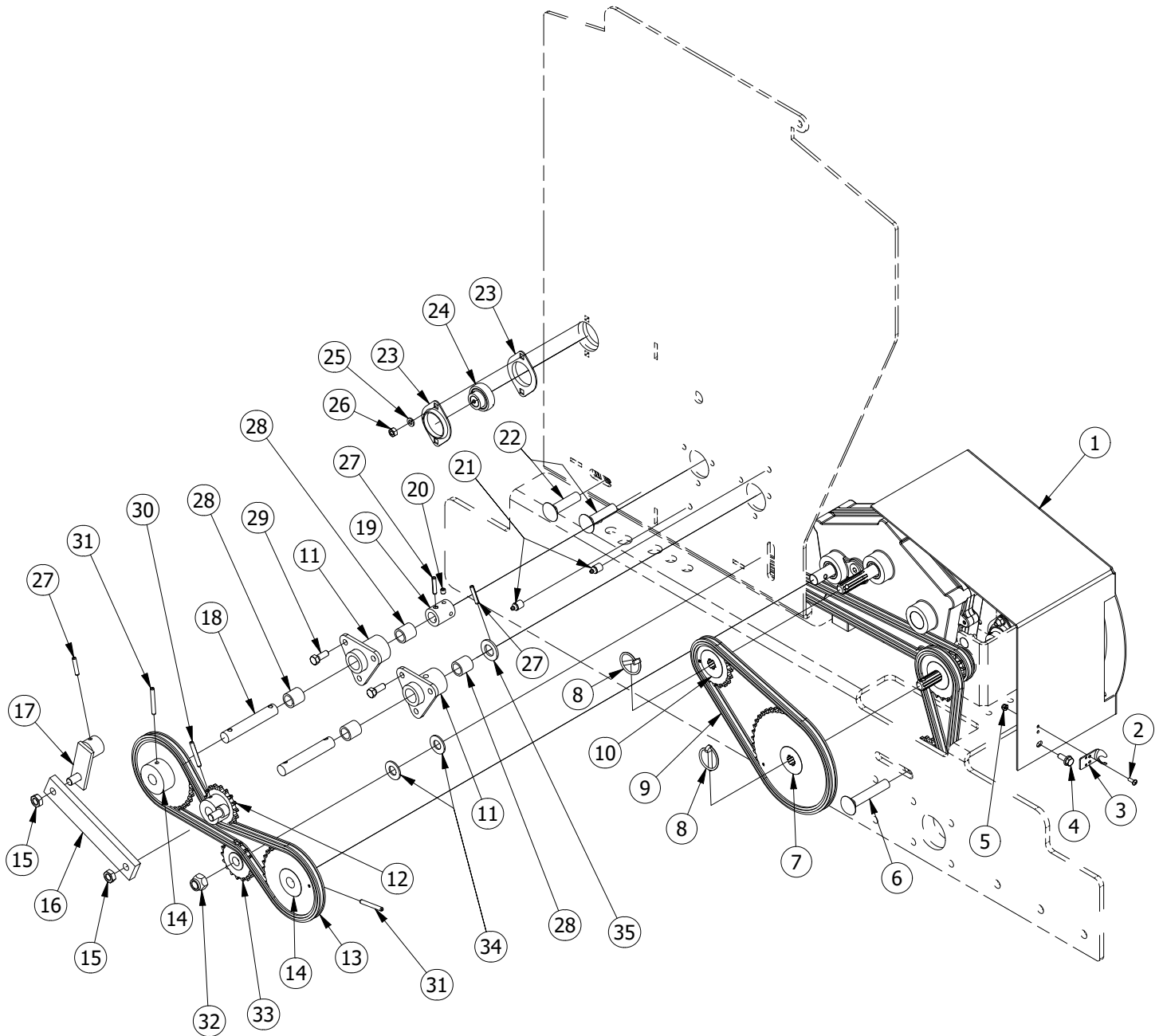

DRIVE ASSEMBLY - OUTSIDE - 5612 DRILL

PARTS LIST				
ITEM	ITEM QTY	PART NUMBER	DESCRIPTION	COMMENTS
1	1	140320	GEARBOX SHIELD	
2	2	11024022	10 - 24 X 1/2 PAN HEAD SCREW	
3	1	1404	HOOD LATCH SUPPORT	
4	3	12018032	5/16-18 X 0.75 FLANGE BOLT	
5	2	51024002	No. 10 - 24 HEX LOCK NUT	
6	1	24011145	5/8-11 X 3.5 CARRIAGE BOLT	
7	1	1419	SPROCKET - 45T	
8	2	1421	LINCH PIN	
9	1	1420	#40 CHAIN 67 LINKS	
10	1	1418	SPROCKET - 20T	
11	2	141620	TRIANGLE HUB	
12	1	1408	SPROCKET - 17T	
13	1	1426	#40 CHAIN 84 LINKS	
14	2	1410	SPROCKET - 32T	
15	2	53213002	1/2 - 13 HEX JAM NUT	
16	1	1407	AGITATOR LINK	
17	1	1406	AGITATOR ARM	
18	2	1412	SEED BOX JACK SHAFT	
19	1	1411	SQUARE COUPLER	
20	2	1414	5/16-18 X 0.31	
21	2	Z18FP	ZERK	
22	2	24011105	5/8-11 X 2.5 CARRIAGE BOLT	
23	2	1424	BEARING FLANGE	
24	1	1423	BEARING	
25	2	62000000	5/16 LOCK WASHER	
26	2	32018005	5/16 - 18 HEX NUT	
27	3	93160500	1/4 x 1 1/4 ROLL PIN	
28	4	1415	BRONZE BUSHING	
29	6	12416045	3/8-16 UNC X 1 HEX BOLT	
30	1	93160700	1/4 x 1 3/4 ROLL PIN	
31	2	93160800	1/4 x 2 ROLL PIN	
32	1	54011005	5/8 - 11 HEX LOCK NUT	
33	1	1409	IDLER SPROCKET	
34	2	84000000	5/8 SAE WASHER	
35	1	84800000	3/4 SAE WASHER	

DRIVE ASSEMBLY - INSIDE - 5612 DRILL

PARTS LIST				
ITEM	ITEM QTY	PART NUMBER	DESCRIPTION	COMMENTS
22	2	24011105	5/8-11 X 2.5 CARRIAGE BOLT	
23	2	1424	BEARING FLANGE	
24	1	1423	BEARING	
25	2	62000000	5/16 LOCK WASHER	
26	2	32018005	5/16 - 18 HEX NUT	
27	3	93160500	1/4 x 1 1/4 ROLL PIN	
28	4	1415	BRONZE BUSHING	
29	6	12416045	3/8-16 UNC X 1 HEX BOLT	
30	1	93160700	1/4 x 1 3/4 ROLL PIN	
31	2	93160800	1/4 x 2 ROLL PIN	
32	1	54011005	5/8 - 11 HEX LOCK NUT	
33	1	1409	IDLER SPROCKET	
34	2	84000000	5/8 SAE WASHER	
35	1	84800000	3/4 SAE WASHER	
36	1	1401	GEARBOX	
37	2	1417	GREASE HOSE	
38	13	62400000	3/8 LOCK WASHER	
39	9	32416005	3/8 - 16 HEX NUT	
40	1	1435	SPROCKET - 42T	
41	1	144720	#40 CHAIN 199 LINKS	
42	1	145420	SMALL BOX JACK SHAFT	
43	2	72400000	3/8 WASHER	
44	1	144820	#40 CHAIN - 77 LINKS	
45	1	1915	CHAIN TIGHTNER	
46	1	12416085	3/8-16 UNC X 2 HEX BOLT	
47	1	1437	SPROCKET - 16T	
48	8	22018042	5/16-18 X 1 CARRIAGE BOLT	
49	1	3406	FLANGE BEARING	
50	1	1422	SPLINE SHAFT	
51	1	1425	SPROCKET - 22T, 12T	
52	4	12416055	3/8-16 UNC X 1.25 HEX BOLT	
53	1	1428	SPACER	
54	1	1430	ACRE METER SHAFT	
55	1	1451	ACRE METER	
56	1	1433	SHAFT COLLAR	
57	1	143220	SUPPORT	
58	1	Z1428	ZERK	
59	1	1452	SPROCKET - 26T	
60	1	1434	#40 CHAIN 67 LINKS	
61	1	91100400	5/32 x 1 COTTER PIN	
62	1	1402	GEARBOX LEVER	
63	1	33213005	1/2 - 13 HEX NUT	
64	2	73200000	1/2 WASHER	
65	1	1405	KNOB	

GEARBOX - 5612 DRILL

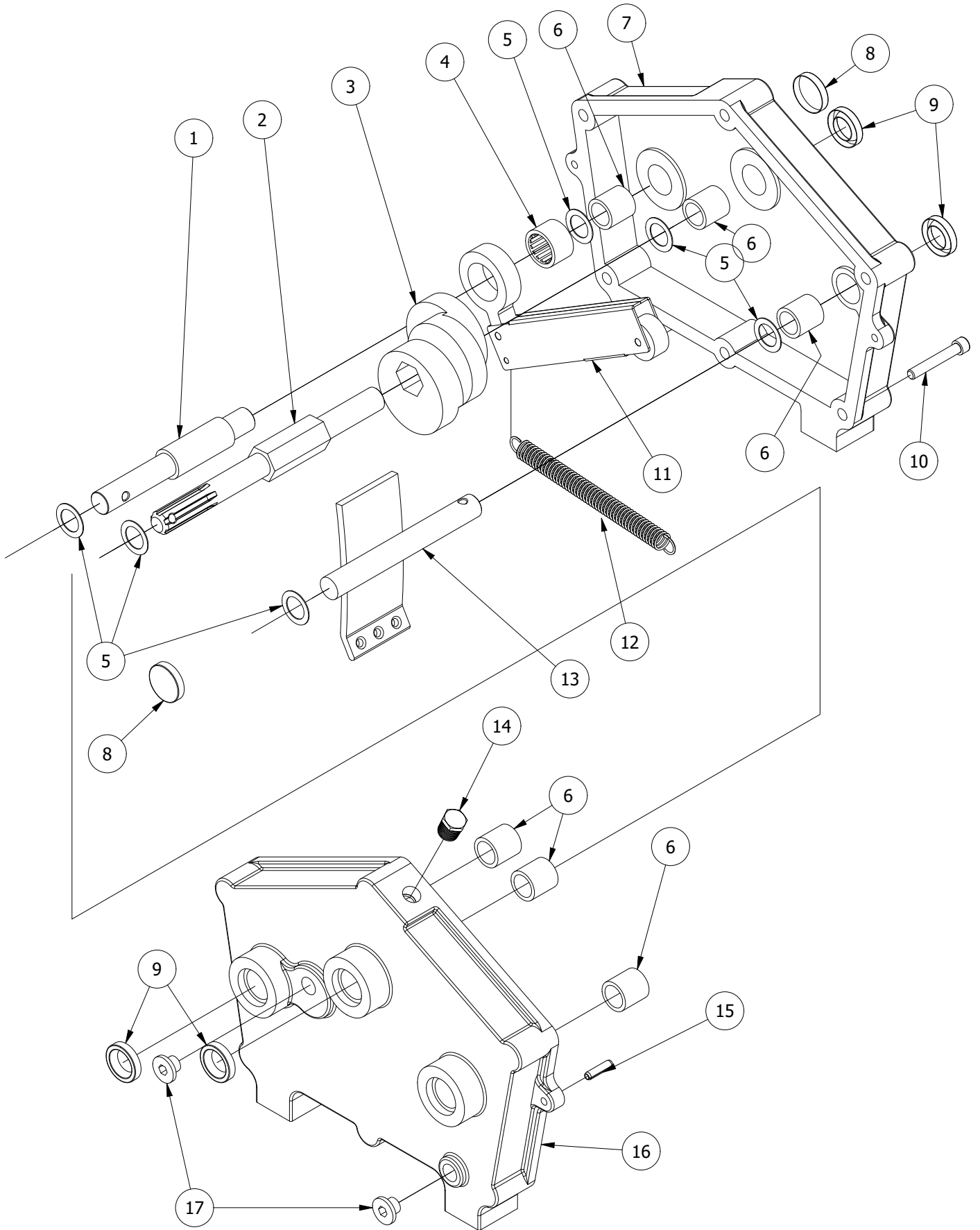

GEARBOX - 5612 DRILL

PARTS LIST				
ITEM	QTY	PART NUMBER	DESCRIPTION	COMMENTS
1	1	1308	CAM ARM SHAFT	
2	1	1304	SHAFT	
3	1	1305	GEARBOX CAM	
4	3	1307	CLUTCH BEARING	
5	6	1316	SHIM WASHER	
6	6	1415	BRONZE BUSHING	
7	1	1301	GEARBOX LEFT CASTING	INCLUDES #1310, 1311, 1415
8	2	1311	CAP	
9	4	1310	SEAL	
10	6	1312	SOCKET HEAD BOLT	
11	3	1306	GEARBOX ARM	
12	3	1309	GEARBOX SPRING	
13	1	1303	CAM GUIDE	
14	1	1315	BREATHER PLUG	
15	2	93160400	1/4 x 1 ROLL PIN	
16	1	1302	GEARBOX RIGHT CASTING	INCLUDES #1310, 1415
17	2	1314	PLUG	

SEED BOX ASSEMBLY - 5612 DRILL

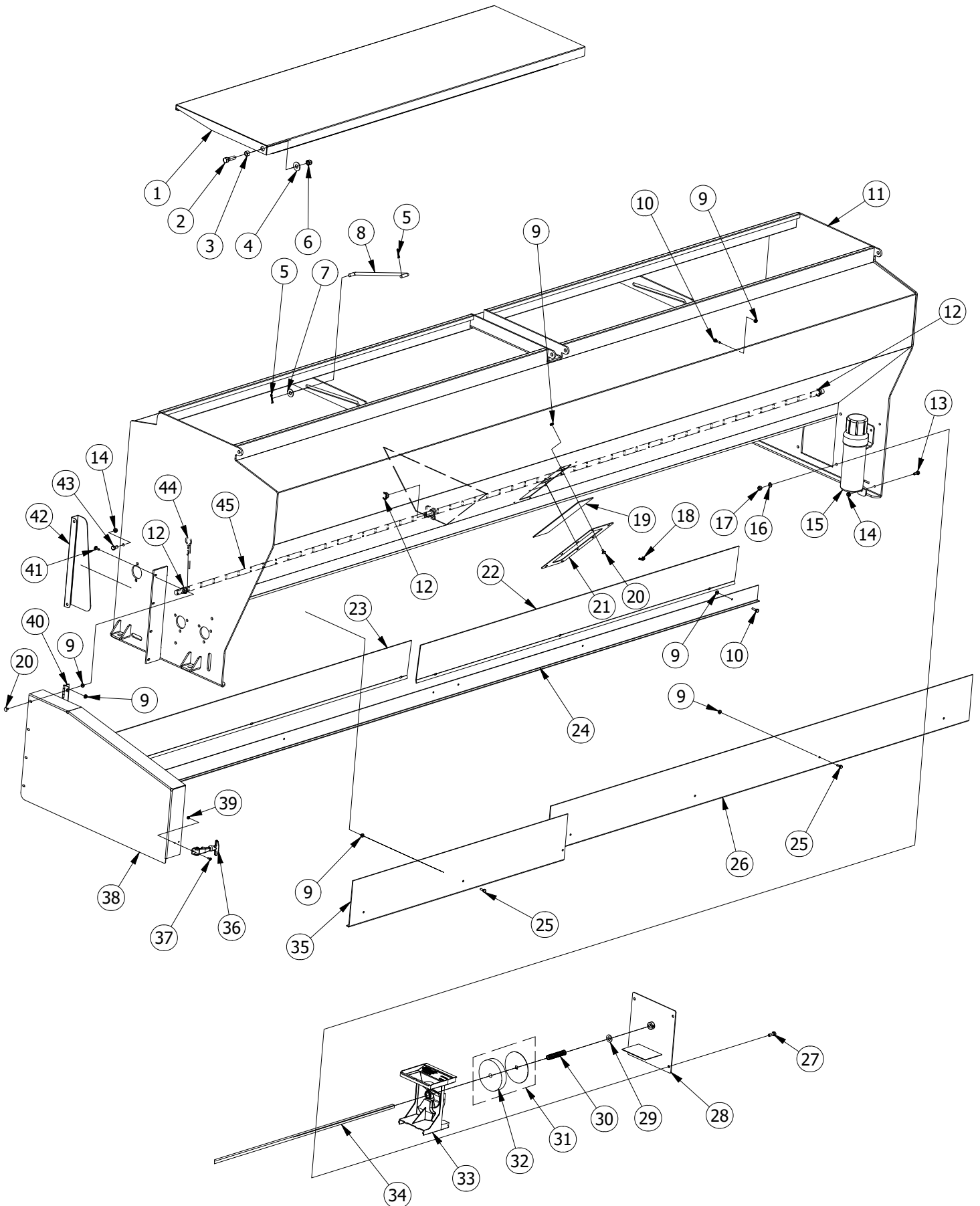

SEED BOX ASSEMBLY - 5612 DRILL

PARTS LIST				
ITEM	QTY	PART #	DESCRIPTION	COMMENTS
1	2	124220	SEED BOX LID	
2	4	13213075	1/2-13 UNC X 1.75 HEX BOLT	
3	4	1658	BUSHING	
4	4	73200000	1/2 WASHER	
5	4	91100400	5/32 x 1 COTTER PIN	
6	4	53213005	1/2 - 13 HEX LOCK NUT	
7	2	72800000	7/16 WASHER	
8	2	1203	LID GUIDE	
9	33	41620005	1/4 - 20 HEX FLANGE NUT	
10	10	11620045	1/4-20 UNC X 1 HEX BOLT	
11	1	125820	SEED BOX	
12	6	1214	BUSHING	
13	2	12018035	5/16-18 UNC X 0.75 HEX BOLT	
14	4	41818005	5/16 - 18 HEX FLANGE NUT	
15	1	1220	MANUAL HOLDER	
16	5	62400000	3/8 LOCK WASHER	
17	4	32416005	3/8 - 16 HEX NUT	
18	6	1207	WING NUT	
19	1	1254	SEED BOX WINDOW	
20	12	21620022	1/4-20 X 0.5 CARRIAGE BOLT	
21	1	125520	SEED BOX WINDOW FRAME	
22	1	124520	SHEILD REMOVABLE- LEFT	
23	1	124820	REAR SHEILD REMOVABLE - RIGHT	
24	1	124420	REAR SHIELD	
25	7	11620035	1/4-20 UNC X 0.75 HEX BOLT	
26	1	1229	FRONT SHIELD - LEFT	
27	4	12416045	3/8-16 UNC X 1 HEX BOLT	
28	1	120820	COVER	
29	25	83600000	9/16 SAE WASHER	
30	25	1212	SPRING	
31	25	1210	FOAM PLATE	
32	25	1211	FOAM	
33	25	1209	SEED CHUTE	
34	1	1246	SEED BOX DRIVE SHAFT	
35	1	1243	FRONT SHIELD - RIGHT	
36	1	1219	HOOD LATCH	
37	2	11024022	10 - 24 X 1/2 PAN HEAD SCREW	
38	1	121820	GEARBOX SHIELD	
39	2	51024002	10 - 24 HEX LOCK NUT	
40	1	121720	HINGE	
41	4	21620032	1/4-20 X 0.75 CARRIAGE BOLT	
42	1	125920	SMALL SEED BOX CHAIN GUARD - 5512	
43	2	12416035	Hex Bolt	
44	51	1216	AGITATOR CLIP	
45	1	1247	AGITATOR SHAFT	

SMALL SEED BOX - 5612 DRILL

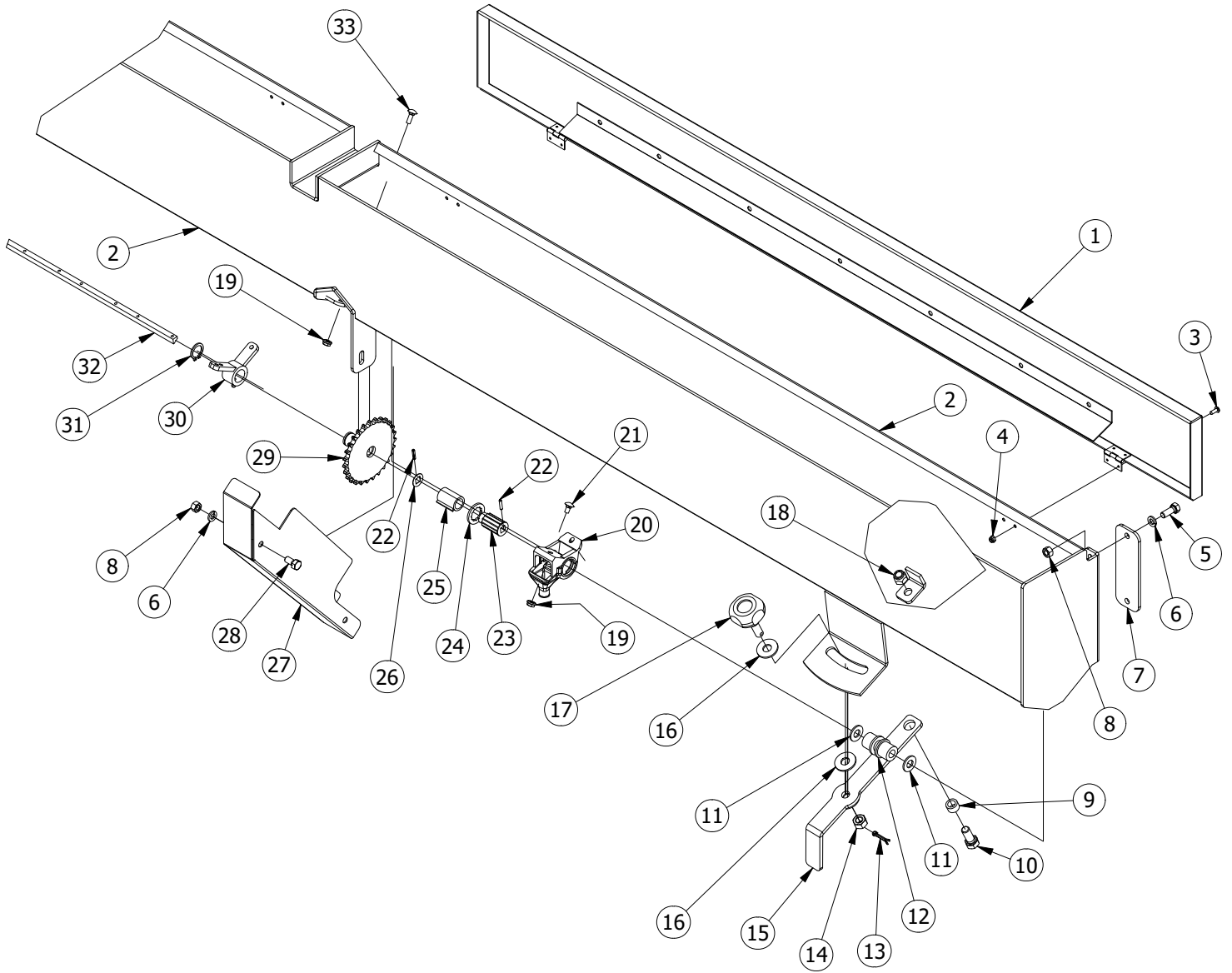

SMALL SEED BOX - 5612 DRILL

PARTS LIST				
ITEM	QTY	PART #	DESCRIPTION	COMMENTS
1	2	194220	LID	
2	1	194520	SMALL SEED BOX	
3	8	11024022	10 - 24 X 1/2 PAN HEAD SCREW	
4	8	51024002	No. 10 - 24 HEX LOCK NUT	
5	4	12416045	3/8-16 UNC X 1 HEX BOLT	
6	5	62400000	3/8 LOCK WASHER	
7	2	190020	SMALL SEED BOX SUPPORT	
8	5	32416005	3/8 - 16 HEX NUT	
9	1	1228	BUSHING	
10	1	13213055	1/2-13 UNC X 1.25 HEX BOLT	
11	2	83200000	1/2 SAE WASHER	
12	1	1909	ADJUSTMENT COLLAR	
13	1	91100400	5/32 x 1 COTTER PIN	
14	1	33213005	1/2 - 13 HEX NUT	
15	1	1910	SMALL BOX LEVER	
16	2	73200000	1/2 WASHER	
17	1	1405	KNOB	
18	1	53213005	1/2 - 13 HEX LOCK NUT	
19	52	41620005	1/4 - 20 HEX FLANGE NUT	
20	25	1904	SEED CUP	
21	51	21620022	1/4-20 X 0.5 CARRIAGE BOLT	
22	50	93100300	ROLL PIN	
23	25	1906	SEED SPROCKET	
24	25	1905	SEED WASHER	
25	25	1907	SLEEVE	
26	25	1908	WASHER	
27	1	194620	SMALL SEEDBOX SHIELD	
28	1	12416035	Hex Bolt	
29	1	1912	SPROCKET 27T	
30	1	1911	BEARING	
31	1	1913	EXTERNAL RETAINING RINGS	
32	1	1943	SMALL SEED BOX SHAFT	
33	2	21620032	1/4-20 X 0.75 CARRIAGE BOLT	

COULTER UNIT - 5612 DRILL

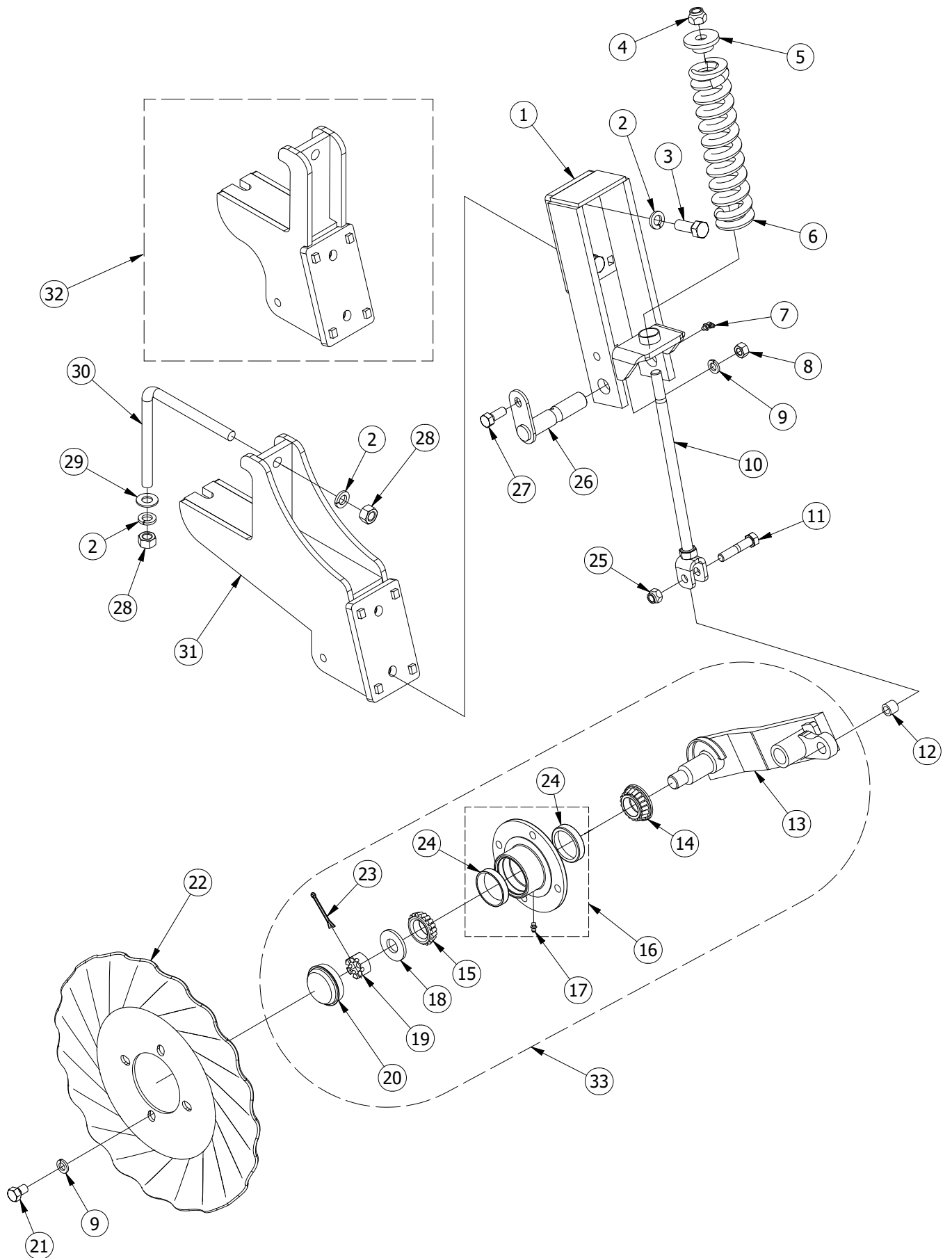

COULTER UNIT - 5612 DRILL

PARTS LIST				
ITEM	QTY	PART NUMBER	DESCRIPTION	COMMENTS
1	25	165320	COULTER ARM MOUNT	
2	100	64000000	5/8 LOCK WASHER	
3	50	14011075	5/8-11 UNC X 1.75 HEX BOLT	
4	25	54011005	5/8 - 11 HEX LOCK NUT	
5	25	1655	COULTER SPRING CAP	
6	25	1656	COULTER SPRING	
7	25	Z1490	ZERK , 90 deg	
8	25	33213005	1/2 - 13 HEX NUT	
9	125	63200000	1/2 LOCK WASHER	
10	25	1657	COULTER SPRING BOLT	
11	25	13213108	1/2-13 UNC X 2.5 HEX BOLT	
12	25	1658	WEAR BUSHING	
13	25	165920	COULTER ARM	
14	25	1660	BEARING WITH SEAL	
15	25	1661	BEARING	
16	25	166520	COULTER HUB	INCLUDES 1662, Z1428
17	13	Z1428	ZERK	
18	25	1667	COULTER SPINDLE WASHER	
19	25	1663	7/8 - 14 SLOTTED HEX NUT	
20	25	166420	HUB CAP	
21	100	13220035	1/2-20 UNF X 0.75 HEX BOLT	
22	25	1666	COULTER BLADE	
23	25	91100800	5/32 x 2 COTTER PIN	
24	50	1662	BEARING CUP	
25	25	53213005	1/2 - 13 HEX LOCK NUT	
26	25	165420	COULTER ARM PIN	
27	25	13213055	1/2-13 UNC X 1.25 HEX BOLT	
28	50	34011005	5/8 - 11 HEX NUT	
29	25	84000000	5/8 SAE WASHER	
30	25	1652	L BOLT	
31	13	165020	LONG MOUNTING BRACKET	
32	12	165120	SHORT MOUNTING BRACKET	
33	25	166920	COULTER ARM ASSEMBLY	

DISC UNIT - 5612 DRILL

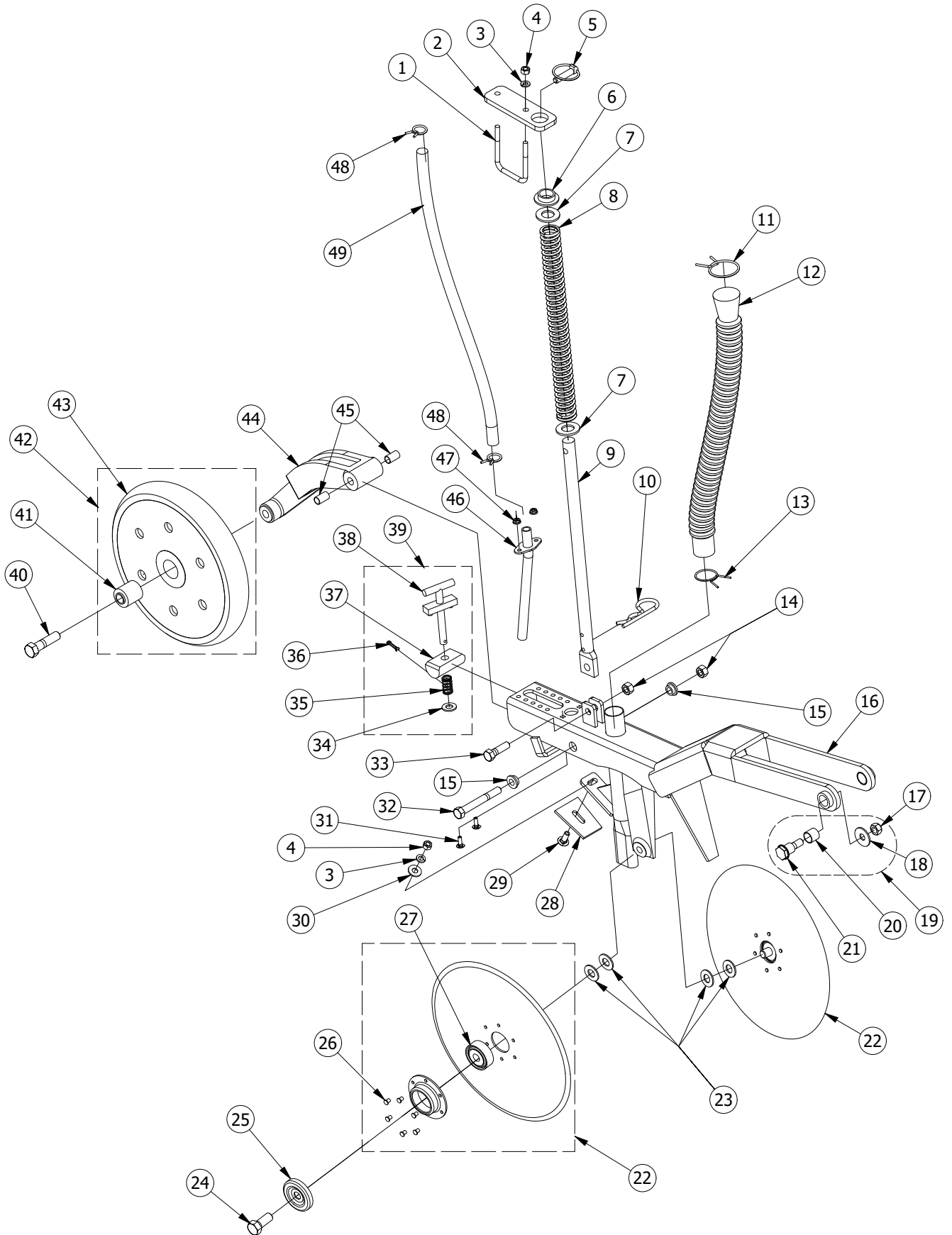

DISC UNIT - 5612 DRILL

PARTS LIST				
ITEM	QTY	PART #	DESCRIPTION	COMMENTS
1	25	1623	U BOLT	
2	25	162220	ROD PLATE	
3	75	62400000	3/8 LOCK WASHER	
4	75	32416005	3/8 - 16 HEX NUT	
5	25	1620	LINCH PIN	
6	25	1621	BUSHING	
7	50	85600000	7/8 SAE WASHER	
8	25	1619	SPRING	
9	25	161720	SPRING ROD	
10	25	1618	HAIRPIN	
11	25	1626	TOP HOSE CLAMP	
12	25	1625	HOSE	
13	25	1624	BOTTOM HOSE CLAMP	
14	50	53213006	1/2 - 13 REV LOCK NUT	
15	50	1608	BUSHING	
16	25	160320	DOUBLE DISC ARM	
17	50	53220008	STOVER LOCK NUT	
18	50	1600	SPRING WASHER	
19	25	1645	WEAR BOLT KIT	
20	50	1642	DISC ARM BUSHING	
21	50	1641	SHOULDER BOLT	
22	50	1605	DISC BLADE	
23	100	84000000	5/8 SAE WASHER	
24	50	14011065	5/8-11 UNC X 1.5 HEX BOLT	
25	50	1604	DUST CAP	
26	50	1627	BOLT KIT	
27	50	1606	BEARING	
28	25	1607	SCRAPER	
29	25	22416042	3/8-16 X 1 CARRIAGE BOLT	
30	25	72400000	3/8 WASHER	
31	50	21620032	1/4-20 X 0.75 CARRIAGE BOLT	
32	25	13213168	1/2-13 UNC X 4 HEX BOLT	
33	25	13213075	1/2-13 UNC X 1.75 HEX BOLT	
34	25	83200000	1/2 SAE WASHER	
35	25	1613	SPRING	
36	25	91100400	5/32 x 1 COTTER PIN	
37	25	1612	DEPTH BLOCK	
38	25	1611	T HANDLE	
39	25	1628	T HANDLE ASSEMBLY	
40	25	14011105	5/8-11 UNC X 2.5 HEX BOLT	
41	25	1630	PRESS WHEEL BEARING	
42	25	1610	PRESS WHEEL	
43	25	1631	PRESS WHEEL TIRE	
44	25	160920	PACKER WHEEL ARM	
45	50	1640	PACKER ARM BUSHING	
46	25	161420	SEED TUBE	
47	50	41620005	1/4 - 20 HEX FLANGE NUT	
48	50	1616	SMALL HOSE CLAMP	
49	25	1615	SEED HOSE	

TRANSPORT HYDRAULICS - 5612 DRILL

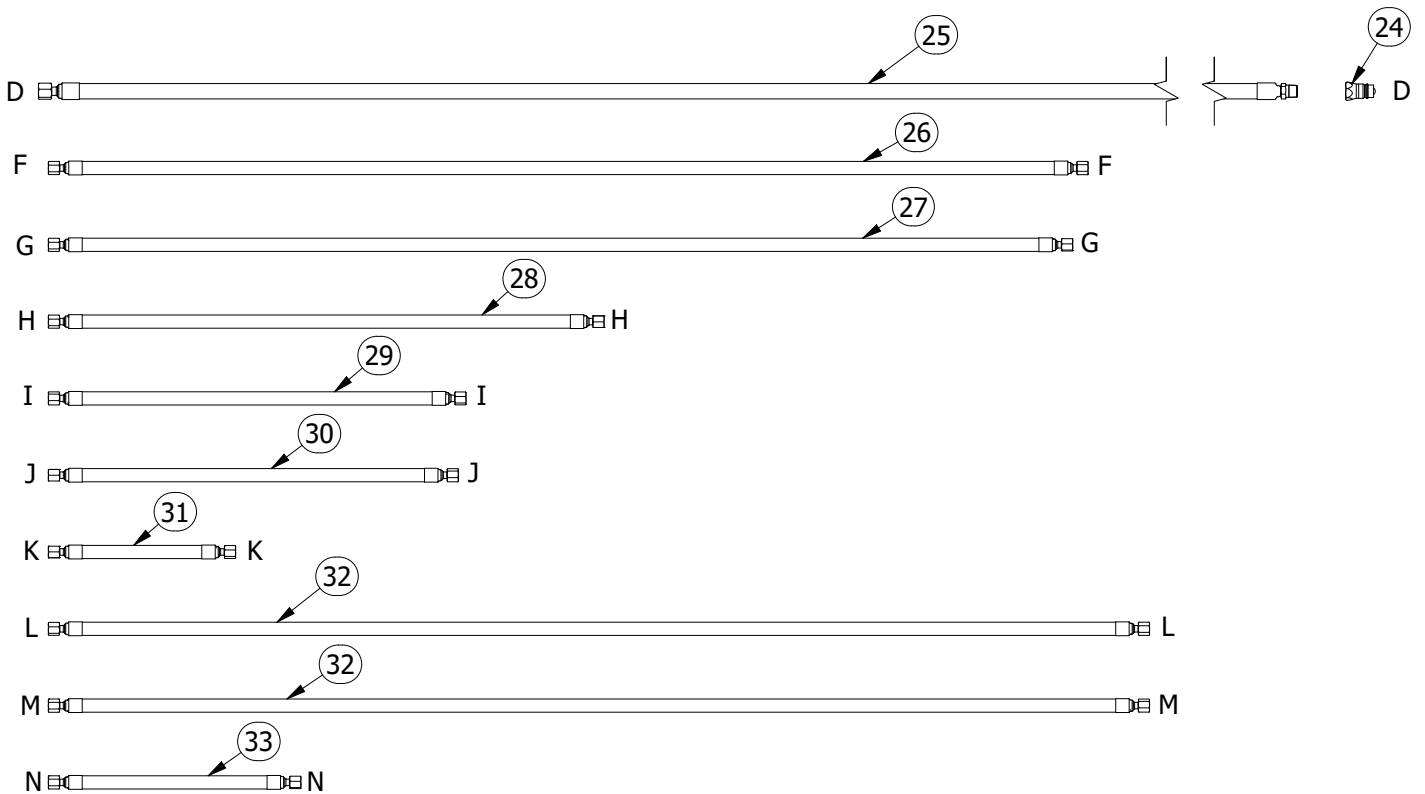
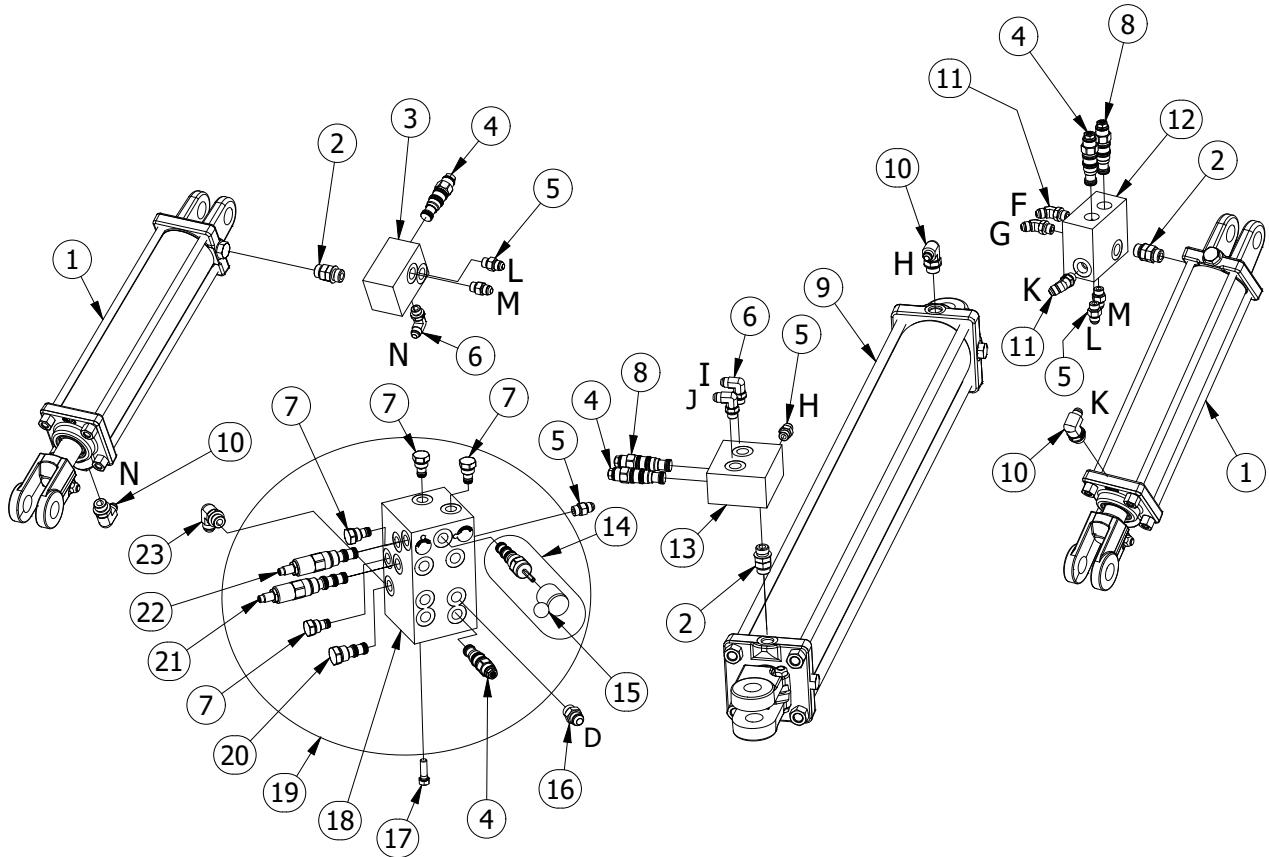

TRANSPORT HYDRAULICS - 5612 DRILL

PARTS LIST				
ITEM	QTY	PART #	DESCRIPTION	COMMENTS
1	2	1147	HYD CYL 3 X 12	SEAL KIT - 1147SK
2	3	640788	ADAPTER	
3	1	1052	MANIFOLD	
4	5	1053	VALVE	
5	9	640066	ADAPTER	
6	3	680166	ADAPTER	
7	4	1071	CHECK VALVE	
8	2	1073	VALVE	
9	1	114620	HYD CYL 4 X 36	SEAL KIT - 104620SK
10	3	680168	ADAPTER	
11	3	680266	ADAPTER	
12	1	1051	DOUBLE MANIFOLD	
13	1	1072	DOUBLE MANIFOLD	
14	1	106720	MANUAL VALVE	
15	1	106720A	MANUAL VALVE KNOB	
16	4	640088	ADAPTER	
17	6	12416055	3/8-16 UNC X 1.25 HEX BOLT	
18	1	106620	MANIFOLD	
19	1	104220	HYDRAULIC VALVE ASSEMBLY	
20	1	1070	CHECK VALVE	
21	1	1069	SEQUENCE VALVE	
22	1	1068	SEQUENCE VALVE	
23	6	680188	ADAPTER	
24	4	1012	MALE QUICK COUPLER	
25	4	1021	HYDRAULIC HOSE	
26	1	1024	HYDRAULIC HOSE	
27	1	1025	HYDRAULIC HOSE	
28	1	1065	HYDRAULIC HOSE	
29	1	1026	HYDRAULIC HOSE	
30	1	1027	HYDRAULIC HOSE	
31	1	1061	HYDRAULIC HOSE	
32	2	1062	HYDRAULIC HOSE	
33	1	1064	HYDRAULIC HOSE	

HYDRAULICS - 5612 DRILL

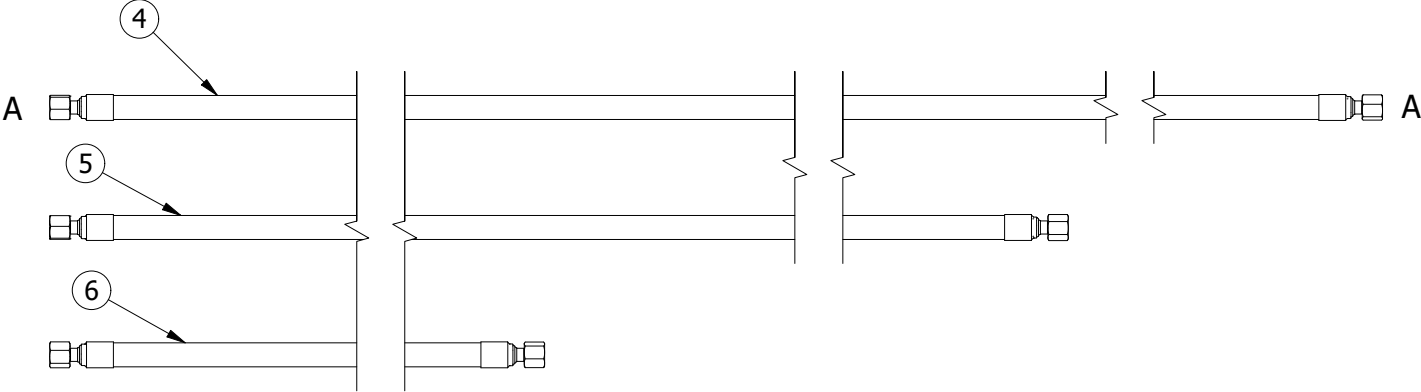
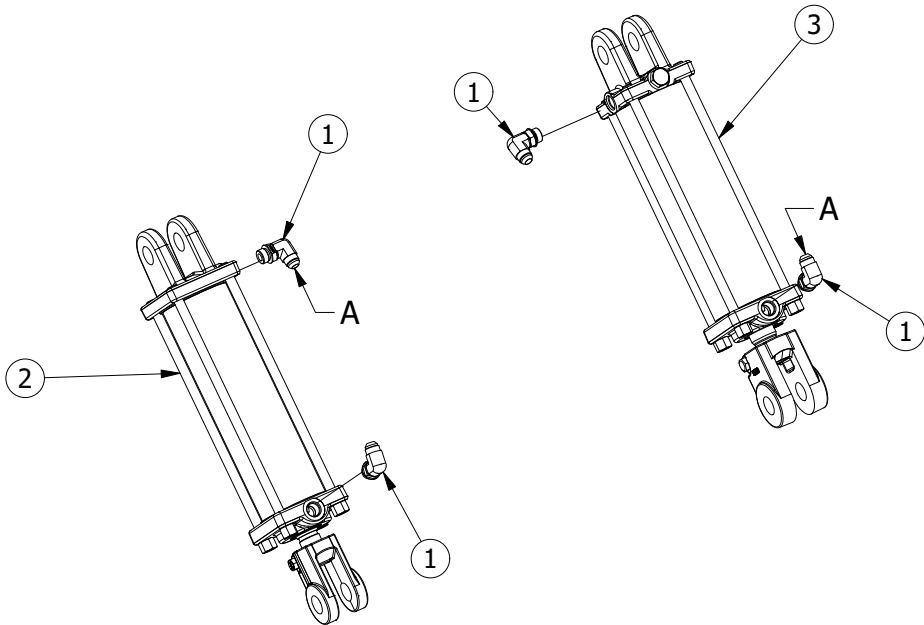

PARTS LIST				
ITEM	QTY	PART #	DESCRIPTION	COMMENTS
1	4	680188	ADAPTER	
2	1	1106	HYDRAULIC CYLINDER	SEAL KIT - 1106SK
3	1	1127	HYDRAULIC CYLINDER	SEAL KIT - 1127SK
4	1	1009	HYDRAULIC HOSE	
5	1	1023	HYDRAULIC HOSE	
6	1	1022	HYDRAULIC HOSE	

DECALS - 5612 DRILL

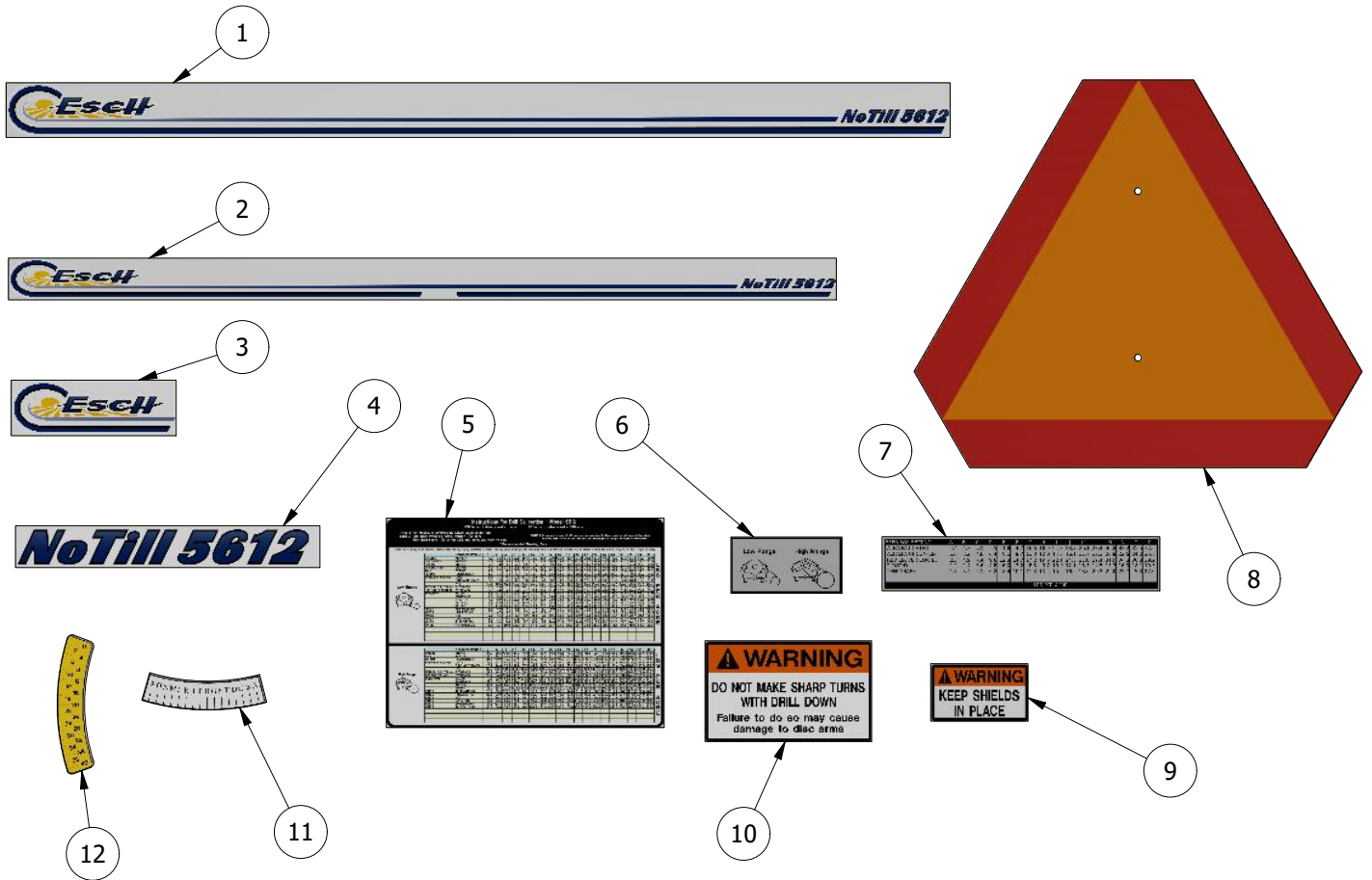

PARTS LIST				
ITEM	QTY	PART #	DESCRIPTION	COMMENTS
1	1	184520	FRONT LOGO DECAL	
2	1	184620	REAR LOGO DECAL	
3	2	1818	SIDE DECAL	
4	2	184820	SIDE DECAL - NO TILL	
5	1	184720	SEED CHART	
6	1	1803	GEARBOX RANGE DECAL	
7	1	1809	SMALL SEED BOX CHART	
8	1	1899	SMV DECAL	
9	2	1805	WARNING SHIELDS DECAL	
10	1	1804	WARNING SHARP TURN DECAL	
11	1	1802	LETTER GAUGE DECAL	
12	1	1801	NUMBER GAUGE DECAL	