

ESCH - FP605 DRILL

Operator's Manual and Parts List



Seed Calibrations and Settings

- Remove plastic from frame (see Fig. A).
- Place plastic under drill to collect seeds for calibration (see Fig. B).
- See seed chart on lid for further instructions. Note: Be sure to turn drive wheel the correct direction. **WARNING: turning drive wheel too fast will result in wrong calibration. Turn wheel at ground speed.**
- When placing seed in hopper, keep seed baffles down (see Fig.C).
- Keep baffles in up position when seeding fluffy seed.

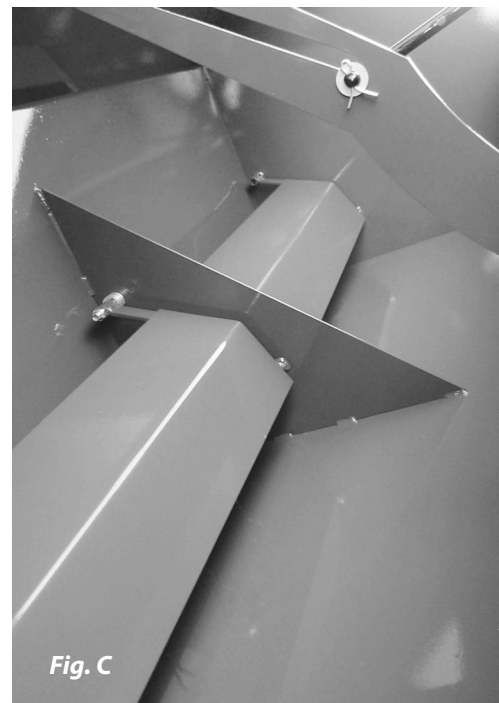
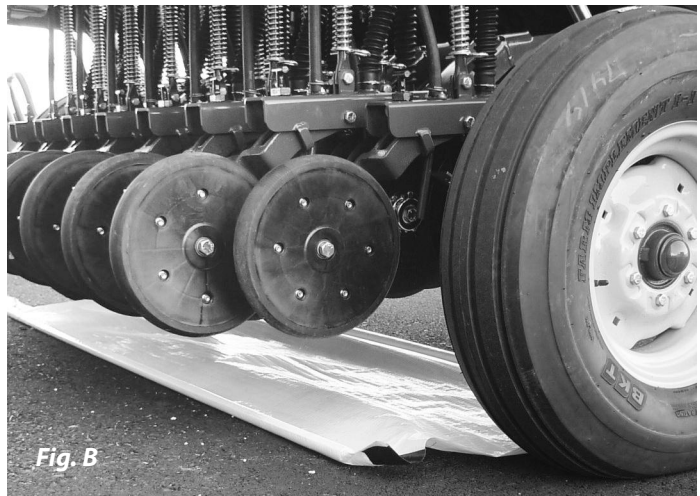
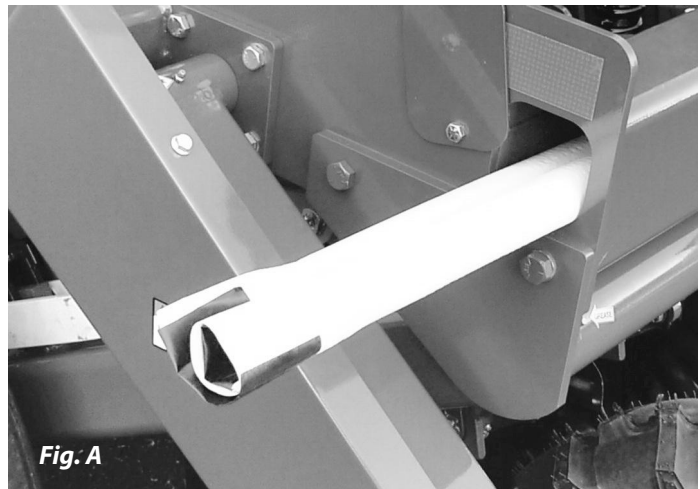

Setting Seeding Depth

- No-till coulters depth can only be set by lowering and raising drill.
- Set no-till coulters approximately 1/2" to 1" deeper than seeding depth.
- Seeding depth can be adjusted by sliding T-handle forward for shallow and backward for deeper.

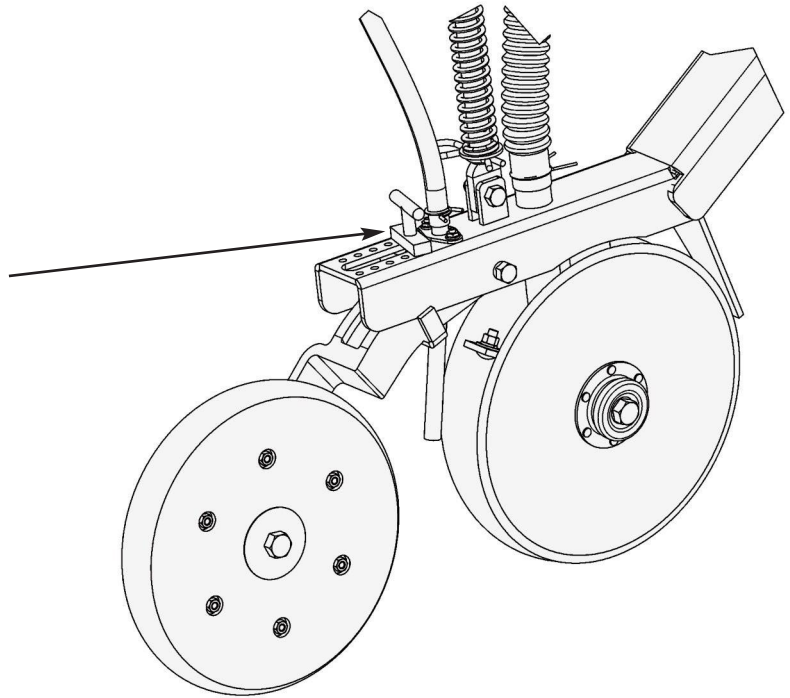

Safety

- Do not ride on drill while moving.
- Do not make sharp turns while drill is down.
- Raise drill when going over rocks that are above ground.

Storage

- Do not store in area where there are lots of mice. Mice like to chew the foams if they can get in the seed box.

Maintenance

- Grease coulters arms: every 10 hours. **(A)**
- Grease coulters hubs: every 50 hours. **(B)**
- Grease all other zerks: every 20 hours.

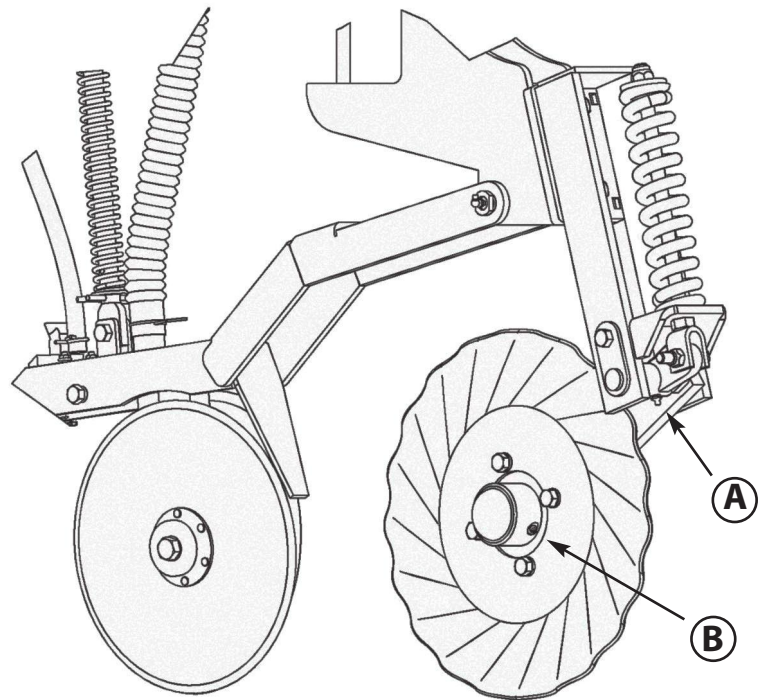

Replacing Foams

- Remove shield on back side of drill (wing nuts).
- Remove shield on left side of seed box.
- Loosen set screws where square shaft slides into round coupler.
- Now shaft is ready to pull out.
- Foam can be cut from plate with a sharp knife or razor.
- Set foams and plate on a piece of card board.
- Spray foams and plates with a spray adhesive.
- Leave set for approximately 1 minute before setting foam on plate.

Trouble Shooting

1 - Seed flows faster on one row:

Foam may be torn or mouse may have chewed a hole in the foam.

2 - One side of drill is lower than other side:

Raise drill the whole way up to reallign.

FRAME ASSEMBLY - FP605 DRILL

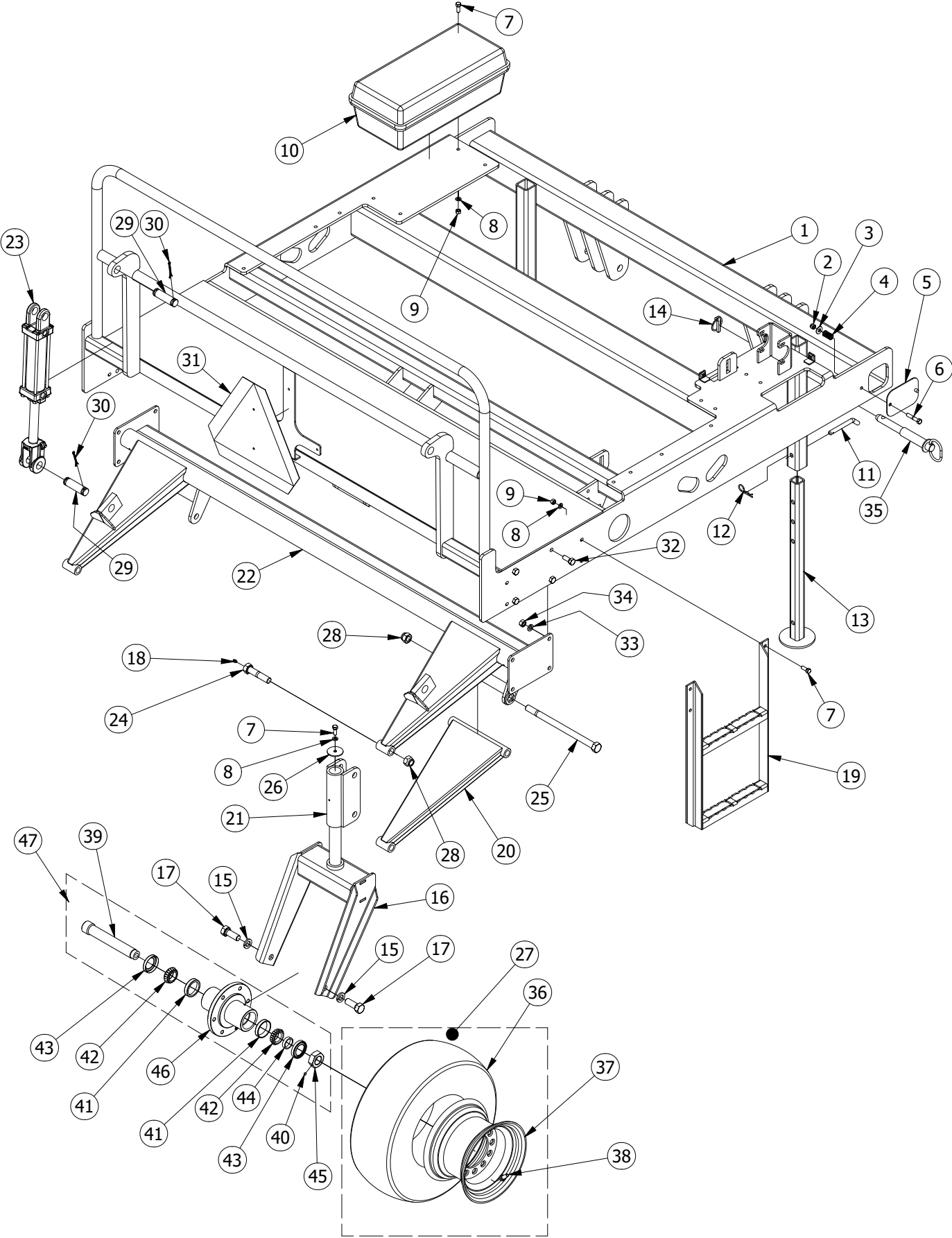

FRAME ASSEMBLY - FP605 DRILL

PARTS LIST				
ITEM	QTY	PART NUMBER	DESCRIPTION	COMMENTS
1	1	310120	FRAME - FP605	
2	1	52416005	3/8 - 16 HEX LOCK NUT	
3	1	72400000	3/8 WASHER	
4	1	1613	SPRING	
5	1	112320	TARP COVER	
6	1	12416085	3/8-16 UNC X 2 HEX BOLT	
7	10	12416045	3/8-16 UNC X 1 HEX BOLT	
8	10	62400000	3/8 LOCK WASHER	
9	8	32416005	3/8 - 16 HEX NUT	
10	1	1115	TOOL BOX	
11	2	1111	PIN	
12	2	1128	1/8 HAIRPIN	
13	2	312220	TRANSPORT LEG ASSEMBLY	
14	2	1620	LINCH PIN	
15	4	64800000	3/4 LOCK WASHER	
16	2	310620	SWIVEL ARM YOKE	
17	4	14810085	3/4-10 UNC X 2 HEX BOLT	
18	6	Z1428	ZERK	
19	1	312120	FP LADDER	
20	2	310420	LIFT ARM - BOTTOM	
21	2	310520	SWIVEL SUPPORT	
22	1	310220	WHEEL MOUNT ASSEMBLY - FP605	
23	2	3103	2X6 CYLINDER	
24	4	14810145	3/4-10 UNC X 3.5 HEX BOLT	
25	2	14810485	3/4-10 UNC X 12 HEX BOLT	
26	2	310720	SWIVEL WHEEL WASHER	
27	1	3114	WHEEL 20.5X8-10	
28	6	54809005	3/4 - 10 HEX LOCK NUT	
29	4	1124	PIN	
30	8	91100800	5/32 x 2 COTTER PIN	
31	1	1122	SMV	
32	8	13213055	1/2-13 UNC X 1.25 HEX BOLT	
33	10	63200000	1/2 LOCK WASHER	
34	8	33213005	1/2 - 13 HEX NUT	
35	2	3123	CAT 1 AND CAT 2 HITCH PIN	
36	2	3116	SWIVEL WHEEL TIRE	
37	2	311520	RIM	
38	2	1190	VALVE STEM	
39	2	3108	SWIVEL WHEEL SPINDLE	
40	2	3111	Set Screw	
41	4	1159	BEARING CUP	
42	4	1160	BEARING	
43	4	3112	SEAL	
44	2	3109	SPINDLE SPACER	
45	2	3110	Hex Nut	
46	2	311320	SWIVEL WHEEL HUB	
47	1	3117	SWIVEL WHEEL HUB ASSEMBLY	

DRIVE ARM - FP605 DRILL

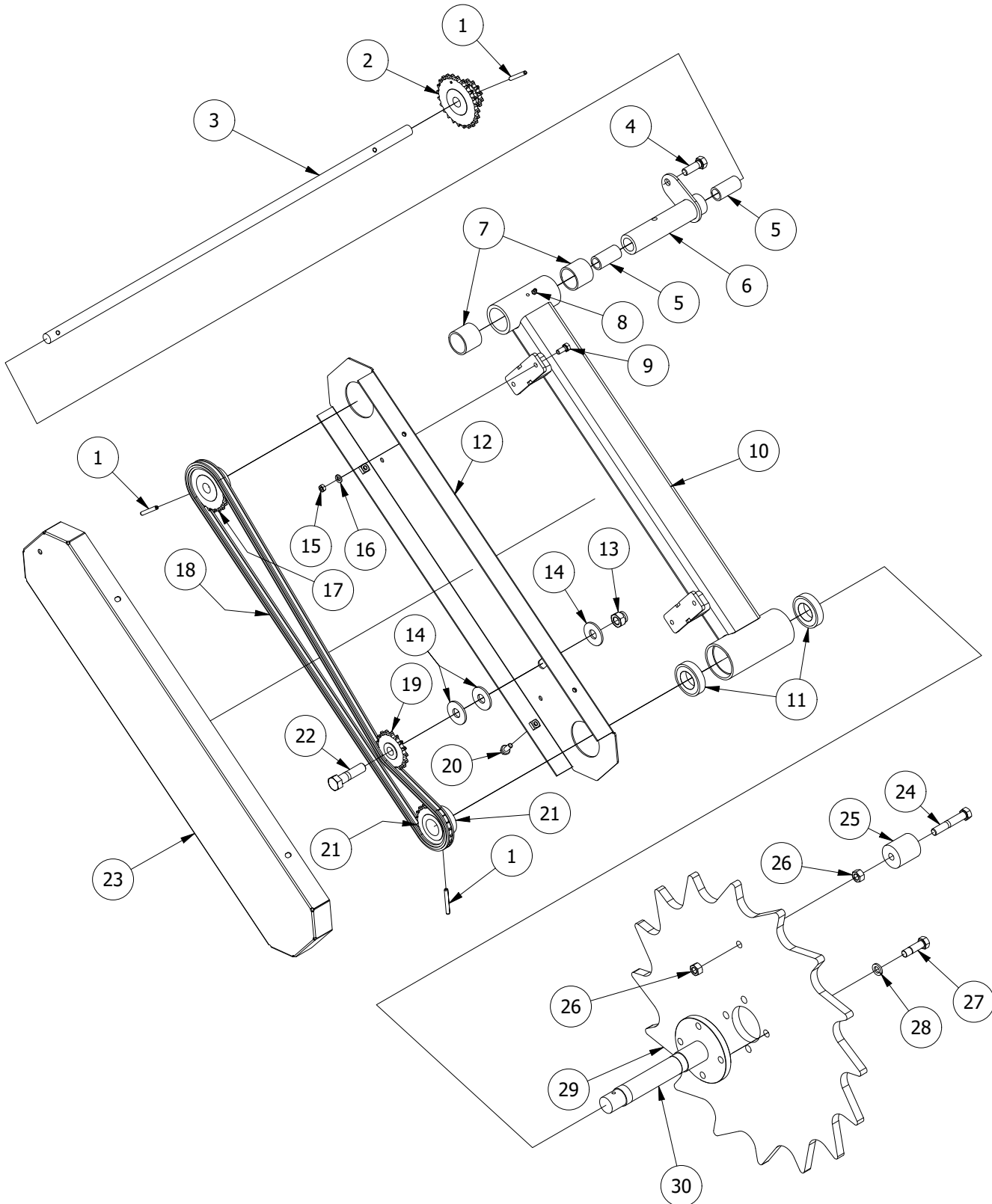

DRIVE ARM - FP605 DRILL

PARTS LIST				
ITEM	QTY	PART NUMBER	DESCRIPTION	COMMENTS
1	3	93160800	1/4 x 2 ROLL PIN	
2	1	3402	SPROCKET - 24T, 12T	
3	1	3502	DRIVE SHAFT	
4	1	13213065	1/2-13 UNC X 1.5 HEX BOLT	
5	2	1519	BUSHING	
6	1	350120	DRIVE WHEEL ARM PIN	
7	2	1518	BUSHING	
8	1	Z1428	ZERK	
9	4	12018035	5/16-18 UNC X 0.75 HEX BOLT	
10	1	153120	DRIVE WHEEL ARM	
11	2	153320	BEARING	
12	1	153520	DRIVE ARM INNER SHIELD	
13	1	54011005	5/8 - 11 HEX LOCK NUT	
14	3	74000000	5/8 WASHER	
15	4	31620005	1/4 - 20 HEX NUT	
16	4	62000000	5/16 LOCK WASHER	
17	1	1527	SPROCKET - 22T	
18	1	3507	#40 CHAIN 135 LINKS	
19	1	1409	IDLER SPROCKET	
20	4	12018032	5/16-18 X 0.75 FLANGE BOLT	
21	1	3504	SPROCKET - 20T	
22	1	14011105	5/8-11 UNC X 2.5 HEX BOLT	
23	1	153620	DRIVE ARM OUTER SHEILD	
24	1	13213128	1/2-13 UNC X 3 HEX BOLT	
25	1	1511	SLEEVE	
26	2	33213005	1/2 - 13 HEX NUT	
27	4	13220075	1/2-20 UNF X 1.75 HEX BOLT	
28	4	63200000	1/2 LOCK WASHER	
29	1	1521	STEEL DRIVE WHEEL	
30	1	153220	DRIVE WHEEL SPINDLE	

DRIVE ASSEMBLY - OUTSIDE - FP605 DRILL

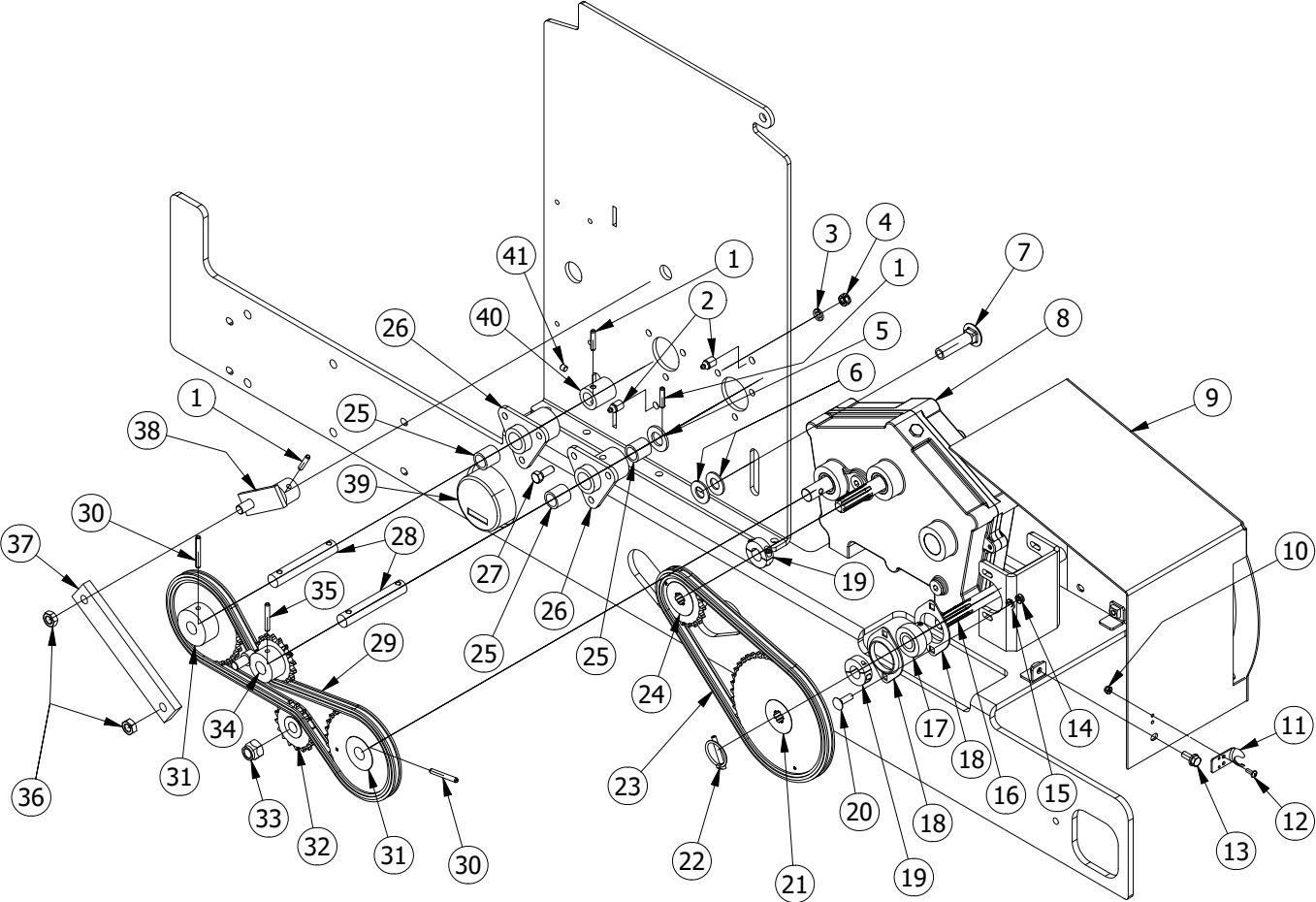

DRIVE ASSEMBLY - OUTSIDE - FP605 DRILL

PARTS LIST				
ITEM	QTY	PART NUMBER	DESCRIPTION	COMMENTS
1	4	93160500	1/4 x 1 1/4 ROLL PIN	
2	2	Z18FP	ZERK	
3	10	62400000	3/8 LOCK WASHER	
4	6	32416005	3/8 - 16 HEX NUT	
5	1	84800000	3/4 SAE WASHER	
6	2	84000000	5/8 SAE WASHER	
7	1	24011105	5/8-11 UNC X 2.5	
8	1	1401	GEARBOX	
9	1	140320	GEARBOX SHIELD	
10	2	51024002	No. 10 - 24 HEX LOCK NUT	
11	1	1404	HOOD LATCH SUPPORT	
12	2	11024022	10 - 24 X 1/2	
13	3	12018032	5/16-18 X 0.75 FLANGE BOLT	
14	4	31620005	1/4 - 20 HEX NUT	
15	4	62000000	5/16 LOCK WASHER	
16	1	1422	SPLINE SHAFT	
17	2	1423	BEARING	
18	4	1424	BEARING FLANGE	
19	2	1433	SHAFT COLLAR	
20	4	22018042	5/16-18 UNC X 1	
21	1	1419	SPROCKET - 45T	
22	2	1421	LINCH PIN	
23	1	1420	#40 CHAIN 67 LINKS	
24	1	1418	SPROCKET - 20T	
25	4	1415	BRONZE BUSHING	
26	2	141620	TRIANGLE HUB	
27	6	12416045	3/8-16 UNC X 1 HEX BOLT	
28	2	1412	SEED BOX JACK SHAFT	
29	1	1426	#40 CHAIN 84 LINKS	
30	5	93160800	1/4 x 2 ROLL PIN	
31	2	1410	SPROCKET - 32T	
32	2	1409	IDLER SPROCKET	
33	1	54011005	5/8 - 11 HEX LOCK NUT	
34	1	1408	SPROCKET - 17T	
35	1	93160700	1/4 x 1 3/4 ROLL PIN	
36	2	53213002	1/2 - 13 HEX JAM NUT	
37	1	1407	AGITATOR LINK	
38	1	1406	AGITATOR ARM	
39	1	1440	ACRE METER	
40	1	1411	SQUARE COUPLER	
41	2	1414	5/16-18 X 0.31	

DRIVE ASSEMBLY - INSIDE - FP605 DRILL

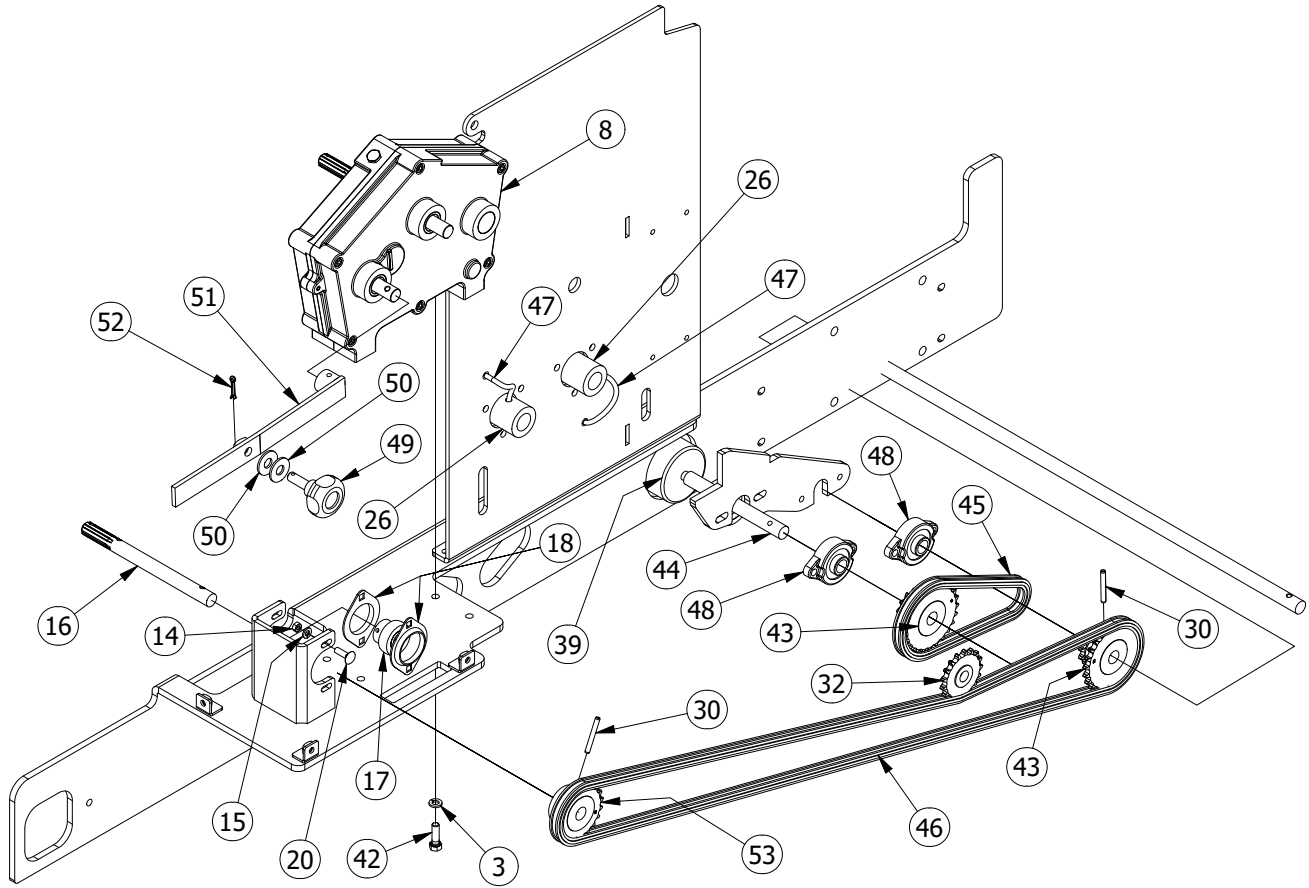

DRIVE ASSEMBLY - INSIDE - FP605 DRILL

PARTS LIST			
ITEM	QTY	PART NUMBER	DESCRIPTION
1	4	93160500	1/4 x 1 1/4 ROLL PIN
3	10	62400000	3/8 LOCK WASHER
8	1	1401	GEARBOX
14	4	31620005	1/4 - 20 HEX NUT
15	4	62000000	5/16 LOCK WASHER
16	1	1422	SPLINE SHAFT
17	2	1423	BEARING
18	4	1424	BEARING FLANGE
20	4	22018042	5/16-18 UNC X 1
26	2	141620	TRIANGLE HUB
30	5	93160800	1/4 x 2 ROLL PIN
32	2	1409	IDLER SPROCKET
39	1	1440	ACRE METER
42	4	12416055	3/8-16 UNC X 1.25 HEX BOLT
43	2	3402	SPROCKET - 24T, 12T
44	1	1430	ACRE METER SHAFT
45	1	3404	#40 CHAIN 45 LINKS
46	1	3403	#40 CHAIN 182 LINKS
47	2	1417	GREASE HOSE
48	3	3406	FLANGE BEARING
49	1	1405	KNOB
50	2	73200000	1/2 WASHER
51	1	1402	GEARBOX LEVER
52	1	91100400	5/32 x 1 COTTER PIN
53	1	3405	SPROCKET - 20T

GEARBOX - FP605 DRILL

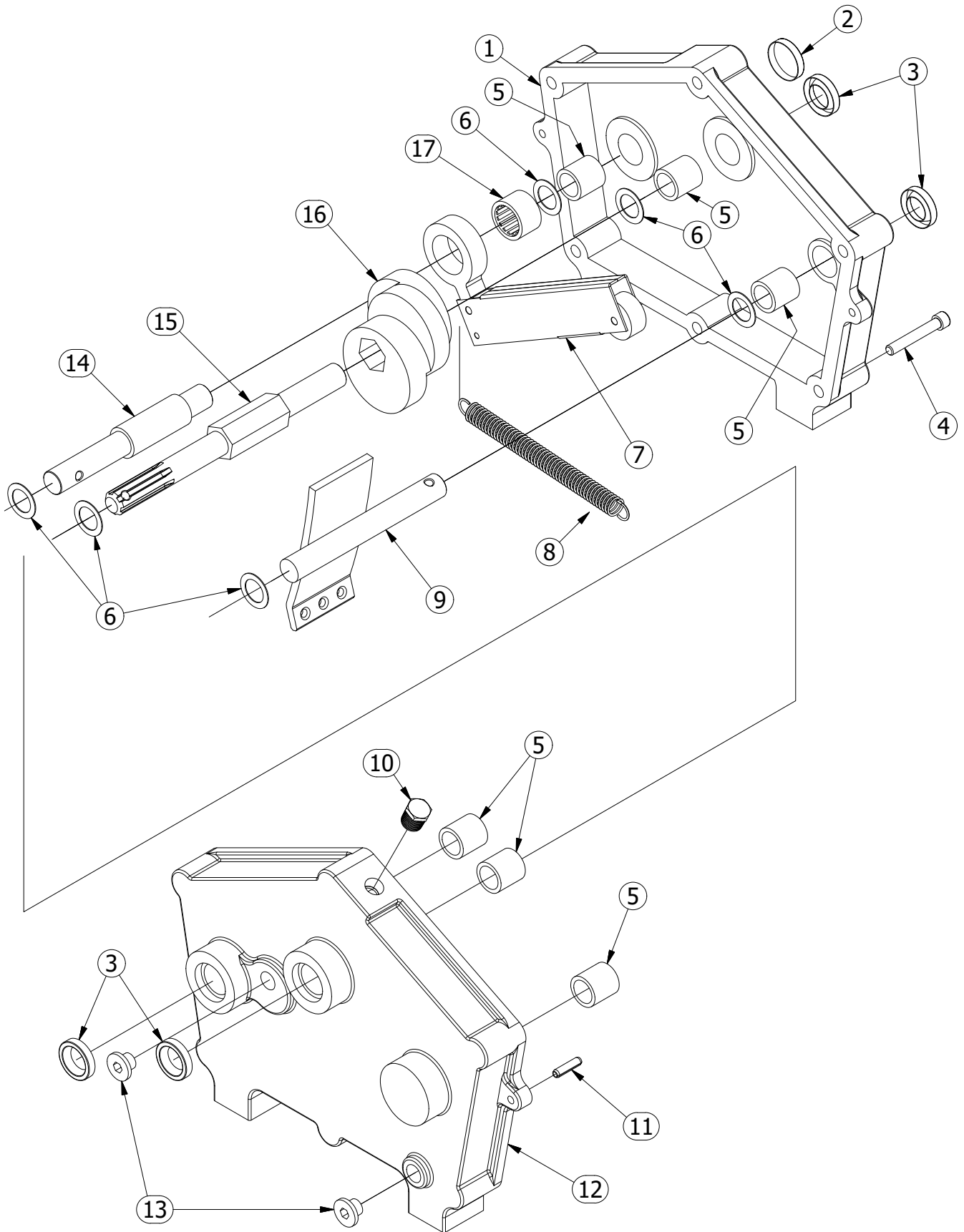

GEARBOX - FP605 DRILL

PARTS LIST				
ITEM	QTY	PART #	DESCRIPTION	COMMENTS
1	1	1301	GEARBOX LEFT CASTING	INCLUDES #1310, 1311, 1415
2	1	1311	CAP	
3	4	1310	SEAL	
4	6	1312	SOCKET HEAD BOLT	
5	6	1415	BRONZE BUSHING	
6	6	1316	SHIM WASHER	
7	3	1306	GEARBOX ARM	
8	3	1309	SPRING	
9	1	1303	CAM GUIDE	
10	1	1315	BREATHER PLUG	
11	2	93160400	ROLL PIN	
12	1	1302	GEARBOX RIGHT CASTING	INCLUDES #1310, 1415
13	2	1314	PLUG	
14	1	1308	SHAFT	
15	1	1304	SHAFT	
16	1	1305	GEARBOX CAM	
17	3	1307	CLUTCH BEARING	

SEED BOX ASSEMBLY - FP605 DRILL

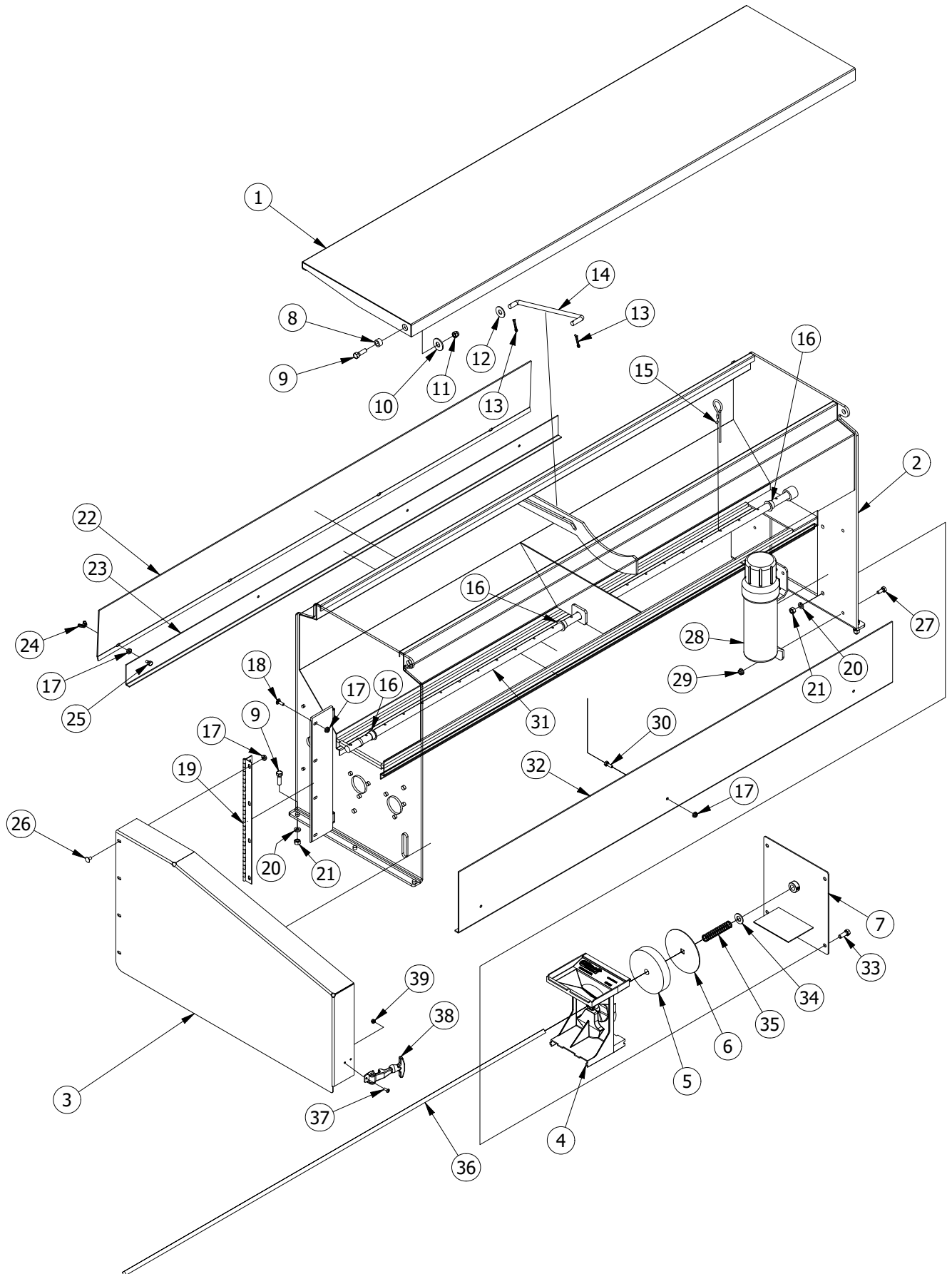

SEED BOX ASSEMBLY - FP605 DRILL

PARTS LIST				
ITEM	QTY	PART NUMBER	DESCRIPTION	COMMENTS
1	1	320220	SEED BOX LID	
2	1	320120	SEED BOX	
3	1	121820	GEARBOX SHIELD	
4	11	1209	SEED CHUTE	
5	11	1211	FOAM	
6	11	1210	FOAM PLATE	
7	1	120820	COVER	
8	2	1658	BUSHING	
9	9	12416055	3/8-16 UNC X 1.25 HEX BOLT	
10	2	73200000	1/2 WASHER	
11	2	52416005	3/8 - 16 HEX LOCK NUT	
12	1	72800000	7/16 WASHER	
13	2	91100400	5/32 x 1 COTTER PIN	
14	1	1238	LID GUIDE	
15	8	1216	AGITATOR CLIP	
16	3	1214	BUSHING	
17	13	41620005	0.25 - 20 HEX FLANGE NUT	
18	4	21620032	1/4-20 UNC X 0.75	
19	1	121720	HINGE	
20	11	62400000	3/8 LOCK WASHER	
21	11	32416005	3/8 - 16 HEX NUT	
22	1	320520	REAR SHEILD REMOVABLE	
23	1	320420	REAR SHIELD	
24	4	1207	WING NUT	
25	4	11620045	1/4-20 UNC X 1 HEX BOLT	
26	4	21620022	1/4-20 UNC X 0.5	
27	2	12018035	5/16-18 UNC X 0.75 HEX BOLT	
28	1	1220	MANUAL HOLDER	
29	2	41818005	0.3125 - 18 HEX FLANGE NUT	
30	1	11620035	1/4-20 UNC X 0.75 HEX BOLT	
31	1	3207	AGITATOR SHAFT	
32	1	3203	FRONT SHIELD	
33	4	12416045	3/8-16 UNC X 1 HEX BOLT	
34	11	83600000	SAE WASHER	
35	11	1212	SPRING	
36	1	3206	SEED BOX DRIVE SHAFT	
37	2	11024022	10 - 24 X 1/2	
38	1	1219	HOOD LATCH	
39	2	51024002	No. 10 - 24 HEX LOCK NUT	

SMALL SEED BOX - FP605 DRILL

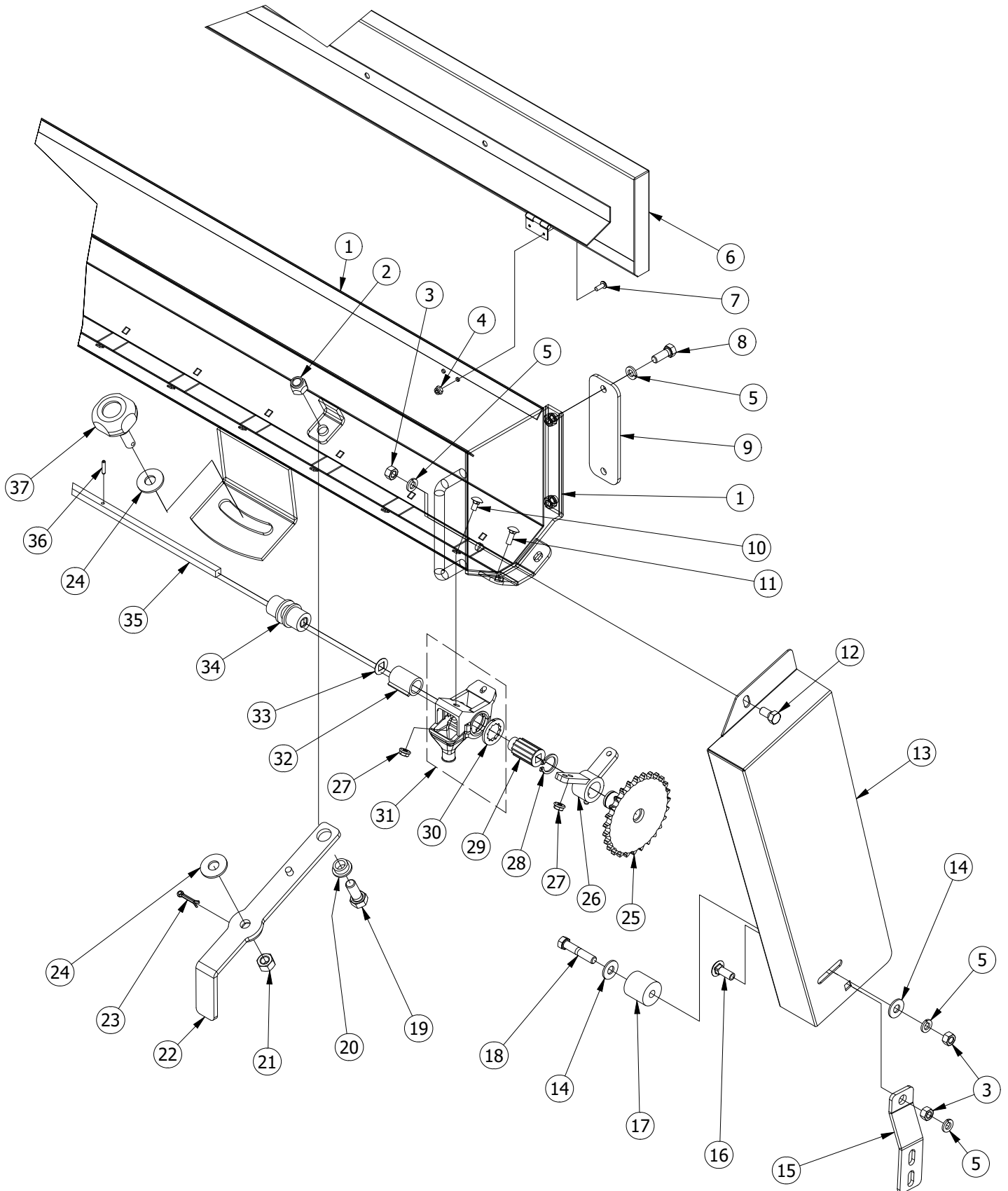

SMALL SEED BOX - FP605 DRILL

PARTS LIST				
ITEM	QTY	PART NUMBER	DESCRIPTION	COMMENTS
1	1	390120	SMALL SEED BOX - FP5	
2	1	53213005	1/2 - 13 HEX LOCK NUT	
3	3	32416005	3/8 - 16 HEX NUT	
4	4	51024002	No. 10 - 24 HEX LOCK NUT	
5	7	62400000	3/8 LOCK WASHER	
6	1	390220	SMALL SEED BOX LID - FP5	
7	4	11024022	10 - 24 X 1/2 PAN HEAD SCREW	
8	4	12416045	3/8-16 UNC X 1 HEX BOLT	
9	2	190020	SMALL SEED BOX SUPPORT	
10	22	21620022	1/4-20 X 0.5 CARRIAGE BOLT	
11	2	21620032	1/4-20 X 0.75 CARRIAGE BOLT	
12	1	12416035	Hex Bolt	
13	1	390520	SMALL SEED BOX SHEILD - 4 ROW	
14	2	72400000	3/8 WASHER	
15	1	390420	SMALL SEED BOX SHEILD SUPPORT	
16	1	22416042	3/8-16 X 1 CARRIAGE BOLT	
17	1	1915	CHAIN TIGHTNER	
18	1	12416085	3/8-16 UNC X 2 HEX BOLT	
19	1	13213055	1/2-13 UNC X 1.25 HEX BOLT	
20	1	1916	SMALL SEED BOX LEVER BUSHING	
21	1	33213005	1/2 - 13 HEX NUT	
22	1	1910	SMALL BOX LEVER	
23	1	91100400	5/32 x 1 COTTER PIN	
24	2	73200000	1/2 WASHER	
25	1	1912	SPROCKET 27T	
26	1	1911	BEARING	
27	24	41620005	1/4 - 20 HEX FLANGE NUT	
28	1	1913	EXTERNAL RETAINING RINGS	
29	11	1906	SEED SPROCKET	
30	11	1905	SEED WASHER	
31	11	1904	SEED CUP	
32	11	1907	SLEEVE	
33	11	1908	WASHER	
34	1	1909	ADJUSTMENT COLLAR	
35	1	3903	SMALL SEED BOX SHAFT - FP5	
36	22	93100300	ROLL PIN	
37	1	1405	KNOB	

COULTER UNIT - FP605 DRILL

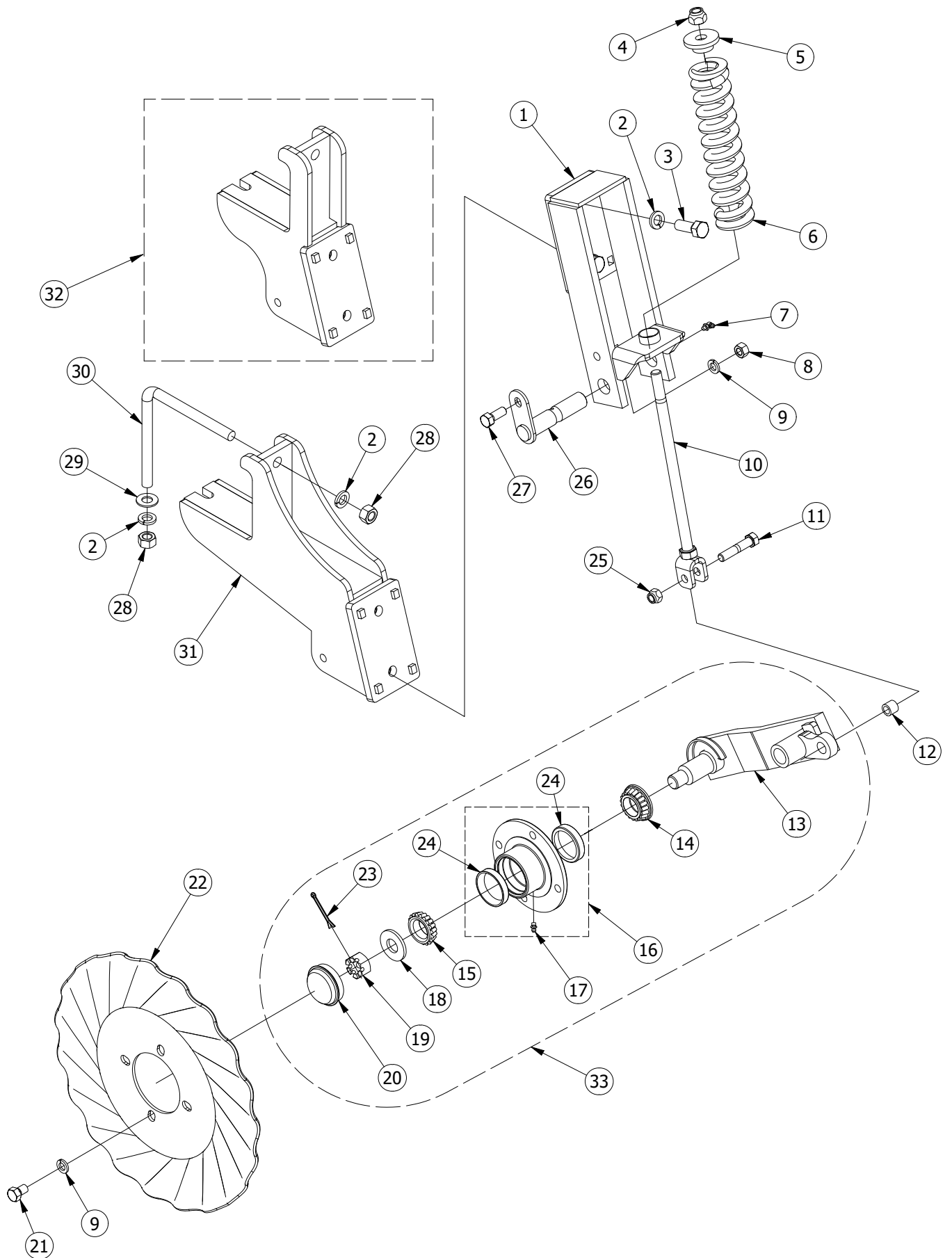

COULTER UNIT - FP605 DRILL

PARTS LIST				
ITEM	QTY	PART NUMBER	DESCRIPTION	COMMENTS
1	11	165320	COULTER ARM MOUNT	
2	44	64000000	5/8 LOCK WASHER	
3	22	14011075	5/8-11 UNC X 1.75 HEX BOLT	
4	11	54011005	5/8 - 11 HEX LOCK NUT	
5	11	1655	COULTER SPRING CAP	
6	11	1656	COULTER SPRING	
7	11	Z1490	ZERK , 90 deg	
8	11	33213005	1/2 - 13 HEX NUT	
9	55	63200000	1/2 LOCK WASHER	
10	11	1657	COULTER SPRING BOLT	
11	11	13213108	1/2-13 UNC X 2.5 HEX BOLT	
12	11	1658	WEAR BUSHING	
13	11	165920	COULTER ARM	
14	11	1660	BEARING WITH SEAL	
15	11	1661	BEARING	
16	11	166520	COULTER HUB	INCLUDES 1662, Z1428
17	6	Z1428	ZERK	
18	11	1667	COULTER SPINDLE WASHER	
19	11	1663	7/8 - 14 SLOTTED HEX NUT	
20	11	166420	HUB CAP	
21	44	13220035	1/2-20 UNF X 0.75 HEX BOLT	
22	11	1666	COULTER BLADE	
23	11	91100800	5/32 x 2 COTTER PIN	
24	22	1662	BEARING CUP	
25	11	53213005	1/2 - 13 HEX LOCK NUT	
26	11	165420	COULTER ARM PIN	
27	11	13213055	1/2-13 UNC X 1.25 HEX BOLT	
28	22	34011005	5/8 - 11 HEX NUT	
29	55	84000000	5/8 SAE WASHER	
30	11	1652	L BOLT	
31	6	165020	LONG MOUNTING BRACKET	
32	5	165120	SHORT MOUNTING BRACKET	
33	11	166920	COULTER ARM ASSEMBLY	

DISC UNIT - FP605 DRILL

PARTS LIST				
ITEM	QTY	PART NUMBER	DESCRIPTION	COMMENTS
1	11	1623	U BOLT	
2	11	162220	ROD PLATE	
3	33	62400000	3/8 LOCK WASHER	
4	33	32416005	3/8 - 16 HEX NUT	
5	11	1620	LINCH PIN	
6	11	1621	BUSHING	
7	22	85600000	7/8 SAE WASHER	
8	11	1619	SPRING	
9	11	161720	SPRING ROD	
10	11	1618	HAIRPIN	
11	11	1626	TOP HOSE CLAMP	
12	11	1625	HOSE	
13	11	1624	BOTTOM HOSE CLAMP	
14	22	53213006	1/2 - 13 REV LOCK NUT	
15	22	1608	BUSHING	
16	11	160320	DOUBLE DISC ARM	
17	22	53213008	STOVER LOCK NUT	
18	22	1600	SPRING WASHER	
19	11	1645	WEAR BOLT KIT	
20	22	1642	DISC ARM BUSHING	
21	22	1641	SHOULDER BOLT	
22	22	1605	DISC BLADE	
23	44	84000000	5/8 SAE WASHER	
24	22	14011065	5/8-11 UNC X 1.5 HEX BOLT	
25	22	1604	DUST CAP	
26	22	1627	BOLT KIT	
27	22	1606	BEARING	
28	11	1607	SCRAPER	
29	11	22416042	3/8-16 X 1 CARRIAGE BOLT	
30	11	72400000	3/8 WASHER	
31	22	21620032	1/4-20 X 0.75 CARRIAGE BOLT	
32	11	13213168	1/2-13 UNC X 4 HEX BOLT	
33	11	13213075	1/2-13 UNC X 1.75 HEX BOLT	
34	11	83200000	1/2 SAE WASHER	
35	11	1613	SPRING	
36	11	91100400	5/32 x 1 COTTER PIN	
37	11	1612	DEPTH BLOCK	
38	11	1611	T HANDLE	
39	11	1628	T HANDLE ASSEMBLY	
40	11	14011105	5/8-11 UNC X 2.5 HEX BOLT	
41	11	1630	PRESS WHEEL BEARING	
42	11	1610	PRESS WHEEL	
43	11	1631	PRESS WHEEL TIRE	
44	11	160920	PACKER WHEEL ARM	
45	22	1640	PACKER ARM BUSHING	
46	11	161420	SEED TUBE	
47	22	41620005	1/4 - 20 HEX FLANGE NUT	
48	22	1616	SMALL HOSE CLAMP	
49	11	1615	SEED HOSE	

HYDRAULICS - FP605 DRILL

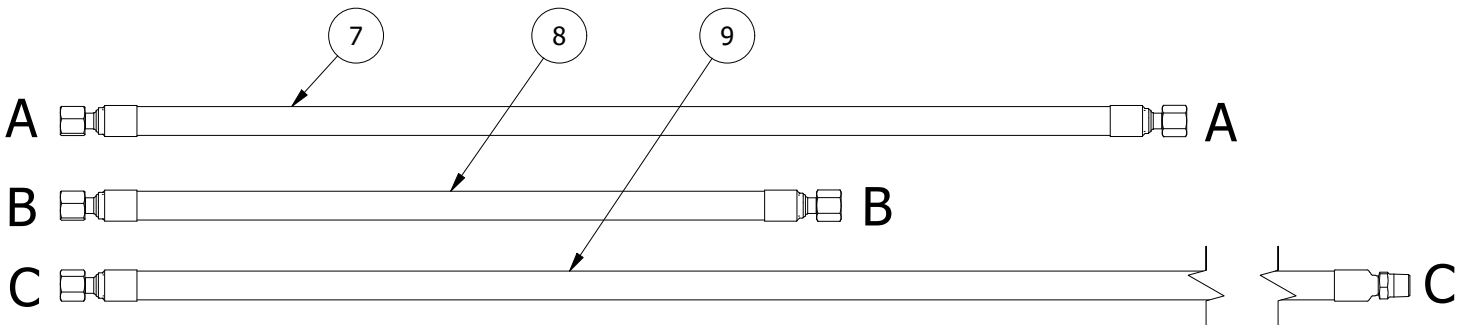
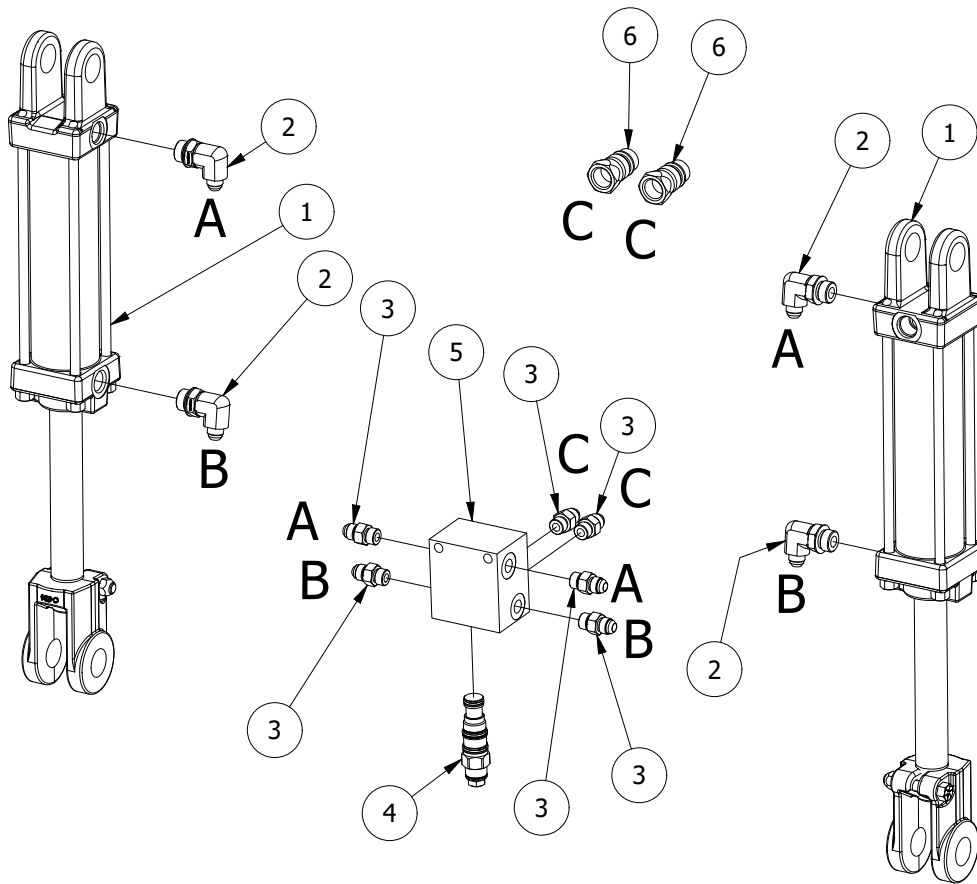

PARTS LIST				
ITEM	QTY	PART #	DESCRIPTION	COMMENTS
1	2	3103	2X6 CYLINDER	
2	4	680168	ADAPTER	
3	6	640066	ADAPTER	
4	1	1053	VALVE	
5	1	3051	FP MANIFOLD	
6	2	1012	MALE QUICK COUPLER	
7	2	3052	HYDRAULIC HOSE	
8	2	3053	HYDRAULIC HOSE	
9	2	3054	HYDRAULIC HOSE	

DECALS - FP605 DRILL

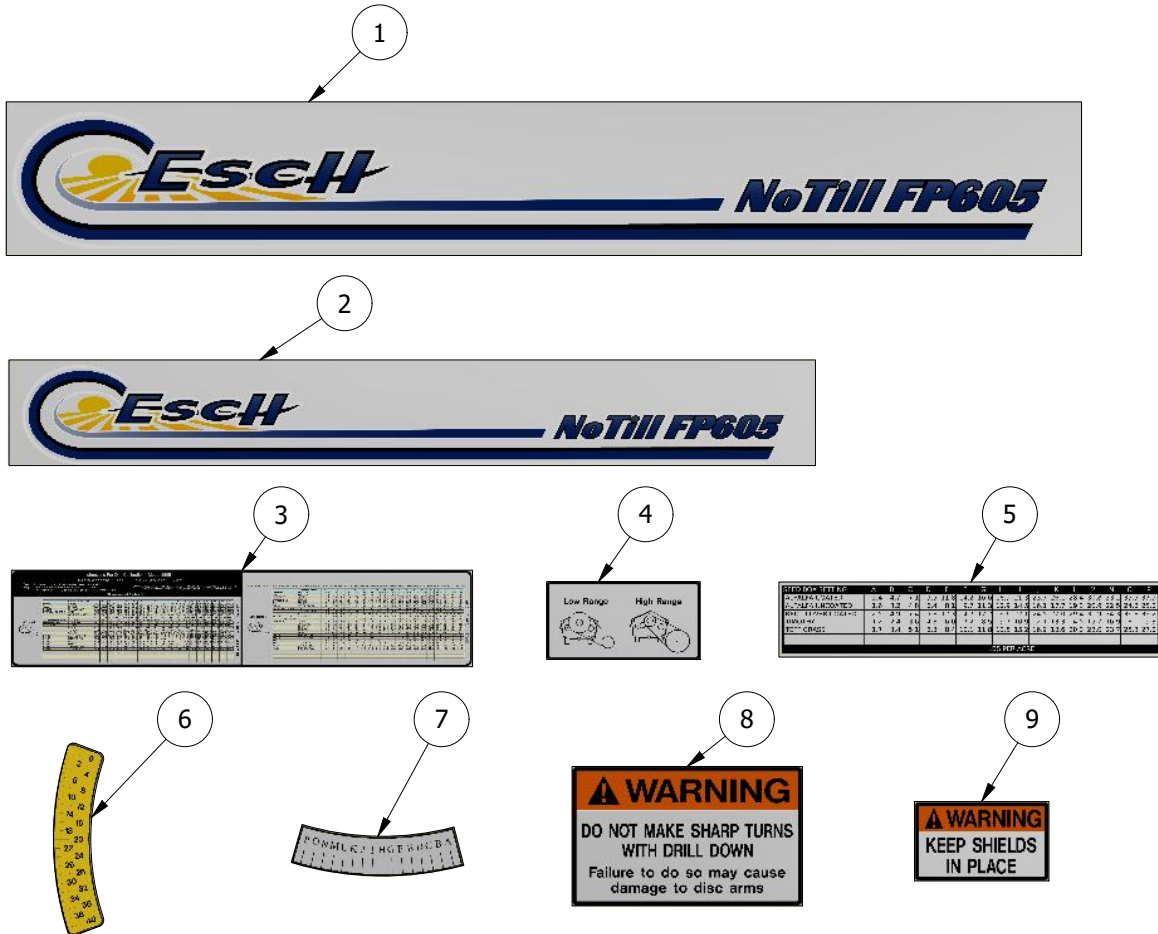

PARTS LIST				
ITEM	QTY	PART NUMBER	DESCRIPTION	COMMENTS
1	1	3801	FP605 - FRONT LOGO DECAL	
2	1	3802	FP605 - REAR LOGO DECAL	
3	1	3803	FP605 - SEED CHART	
4	1	1803	GEARBOX RANGE DECAL	
5	1	1809	SMALL SEED BOX CHART	
6	1	1801	NUMBER GAUGE DECAL	
7	1	1802	LETTER GAUGE DECAL	
8	1	1804	WARNING SHARP TURN DECAL	
9	2	1805	WARNING SHIELDS DECAL	